

Write your name here	
Surname	Other names
Pearson Edexcel International Advanced Level	Centre Number
	Candidate Number
<h1>Physics</h1> Advanced Subsidiary Unit 2: Physics at Work	
Thursday 18 January 2018 – Morning Time: 1 hour 30 minutes	Paper Reference WPH02/01
You do not need any other materials.	Total Marks

Instructions

- Use **black** ink or ball-point pen.
- **Fill in the boxes** at the top of this page with your name, centre number and candidate number.
- Answer **all** questions.
- Answer the questions in the spaces provided
– *there may be more space than you need.*

Information

- The total mark for this paper is 80.
- The marks for **each** question are shown in brackets
– *use this as a guide as to how much time to spend on each question.*
- Questions labelled with an **asterisk** (*) are ones where the quality of your written communication will be assessed
– *you should take particular care with your spelling, punctuation and grammar, as well as the clarity of expression, on these questions.*
- The list of data, formulae and relationships is printed at the end of this booklet.
- Candidates may use a scientific calculator.

Advice

- Read each question carefully before you start to answer it.
- Try to answer every question.
- Check your answers if you have time at the end.

Turn over ►

P51630A

©2018 Pearson Education Ltd.

1/1/1



Pearson

SECTION A

Answer ALL questions.

For questions 1–10, in Section A, select one answer from A to D and put a cross in the box . If you change your mind, put a line through the box and then mark your new answer with a cross .

1 Which of the following is an SI unit for current?

- A Cs
 B Cs⁻¹
 C VΩ
 D ΩV⁻¹

(Total for Question 1 = 1 mark)

2 All the light from a source of power 15 W illuminates a surface of area 140 mm².

Which of the following expressions gives the radiation flux in W m⁻²?

- A $\frac{15}{140 \times 10^{-3}}$
 B $\frac{15}{140 \times 10^{-6}}$
 C $15 \times 140 \times 10^{-3}$
 D $15 \times 140 \times 10^{-6}$

(Total for Question 2 = 1 mark)

3 A sound wave of frequency 160 Hz is travelling in air at a speed of 340 ms⁻¹.

Which of the following expressions gives the phase difference, in radians, between two points on the wave that are 1 m apart?

- A $2\pi \left(\frac{1}{160 \times 340} \right)$
 B $\pi \left(\frac{1}{160 \times 340} \right)$
 C $2\pi \left(\frac{160}{340} \right)$
 D $2\pi \left(\frac{340}{160} \right)$

(Total for Question 3 = 1 mark)

DO NOT WRITE IN THIS AREA

DO NOT WRITE IN THIS AREA

DO NOT WRITE IN THIS AREA



DO NOT WRITE IN THIS AREA

DO NOT WRITE IN THIS AREA

DO NOT WRITE IN THIS AREA

Questions 4 and 5 refer to the following circuit.

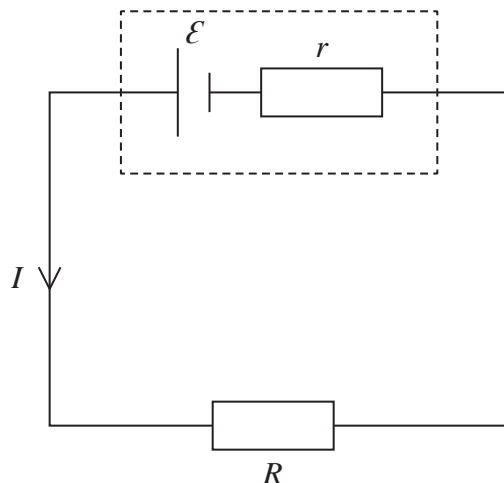

A cell has electromotive force \mathcal{E} and internal resistance r . It supplies a current I to an external circuit with resistance R .

4 Which of the following is an equation for the terminal potential difference V of the cell?

- A $V = \mathcal{E} - Ir$
- B $V = \mathcal{E} + Ir$
- C $V = \frac{\mathcal{E}}{Ir}$
- D $V = Ir$

(Total for Question 4 = 1 mark)

5 Which of the following expressions gives the efficiency of the cell in this circuit?

- A $\frac{\mathcal{E}}{IR}$
- B $\frac{IR}{\mathcal{E}}$
- C $\frac{\mathcal{E}}{I^2R}$
- D $\frac{I^2R}{\mathcal{E}}$

(Total for Question 5 = 1 mark)



6 A source of sound moved away from a stationary observer.

The wavelength and frequency of the sound that reached the observer were compared to the wavelength and frequency of the sound emitted by the source when it was stationary.

Which row of the table shows how the observed wavelength and frequency changed when the source started to move away?

	Wavelength	Frequency
<input type="checkbox"/> A	decreased	decreased
<input type="checkbox"/> B	decreased	increased
<input type="checkbox"/> C	increased	decreased
<input type="checkbox"/> D	increased	increased

(Total for Question 6 = 1 mark)

DO NOT WRITE IN THIS AREA

DO NOT WRITE IN THIS AREA

DO NOT WRITE IN THIS AREA



- 7 A diode is connected in series with a resistor of resistance R and a battery of negligible internal resistance.

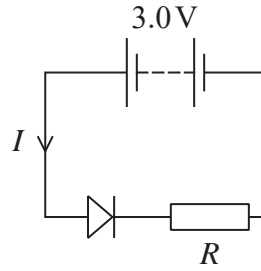

The graph shows the current-potential difference graph for the diode.

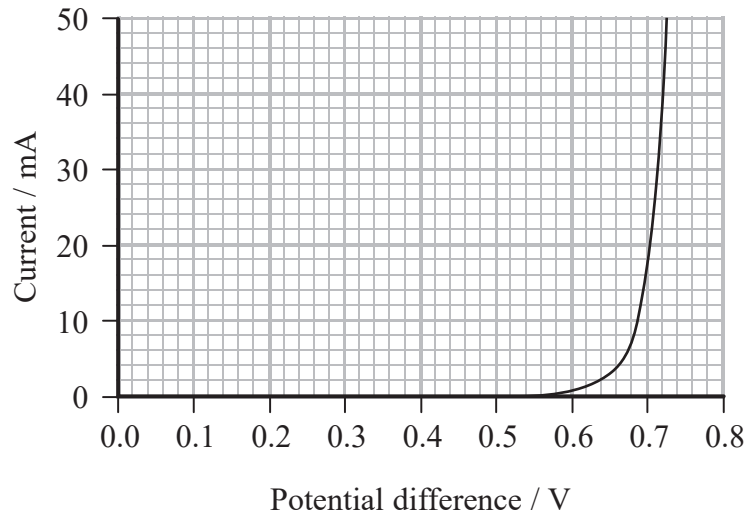

The potential difference across the diode is 0.70 V.

Which of the following expressions gives the resistance R of the resistor?

- A $\frac{0.7}{1.8 \times 10^{-2}}$
- B $\frac{3.0}{1.8 \times 10^{-2}}$
- C $\frac{(3.0 - 0.7)}{1.8 \times 10^{-2}}$
- D $\frac{(3.0 + 0.7)}{1.8 \times 10^{-2}}$

(Total for Question 7 = 1 mark)



8 A monochromatic source of light with a power P emits light with a wavelength λ .

Which of the following expressions gives the number of photons per unit time?

- A $\frac{hc}{P\lambda}$
- B $\frac{P\lambda}{hc}$
- C $\frac{Pc}{h\lambda}$
- D $\frac{h\lambda}{Pc}$

(Total for Question 8 = 1 mark)

9 Which graph shows how the resistance R of a filament bulb varies with temperature θ in $^{\circ}\text{C}$?

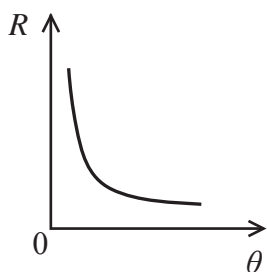

A

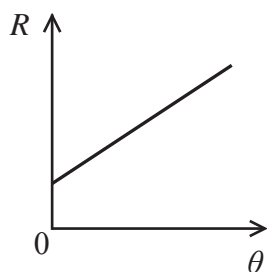

B

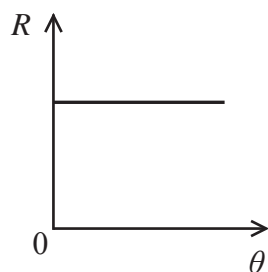

C

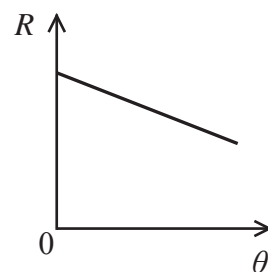

D

(Total for Question 9 = 1 mark)

DO NOT WRITE IN THIS AREA

DO NOT WRITE IN THIS AREA

DO NOT WRITE IN THIS AREA



DO NOT WRITE IN THIS AREA

DO NOT WRITE IN THIS AREA

DO NOT WRITE IN THIS AREA

- 10 Two conducting wires, X and Y, are connected in a series circuit. The wires have the same dimensions but are made from different materials. The charge carrier density in wire X is greater than in wire Y.

Select the row of the table that correctly describes how the current and the drift velocity of the electrons in wire X compare to those in wire Y.

	Current in wire X	Drift velocity in wire X
<input type="checkbox"/> A	same	greater
<input type="checkbox"/> B	same	smaller
<input type="checkbox"/> C	greater	greater
<input type="checkbox"/> D	greater	smaller

(Total for Question 10 = 1 mark)

TOTAL FOR SECTION A = 10 MARKS



DO NOT WRITE IN THIS AREA

DO NOT WRITE IN THIS AREA

DO NOT WRITE IN THIS AREA

BLANK PAGE



SECTION B

Answer ALL questions in the spaces provided.

- 11 A $50\ \Omega$ resistor and a $62\ \Omega$ resistor are connected in series with a battery of negligible internal resistance and e.m.f. $9.0\ \text{V}$, as shown.

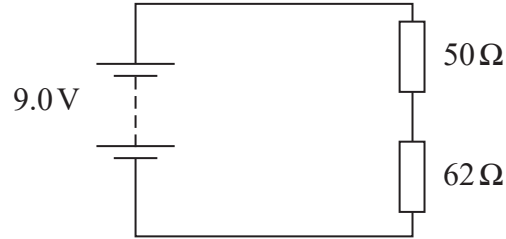

- (a) Calculate the power dissipated in the $62\ \Omega$ resistor.

(3)

Power dissipated =

- (b) A $57\ \Omega$ resistor is connected in parallel with the $62\ \Omega$ resistor as shown below.

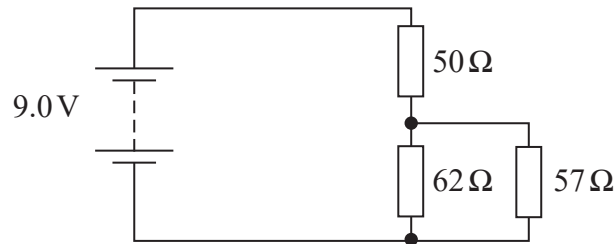

Calculate the total resistance of the circuit.

(3)

Total resistance of circuit =

(Total for Question 11 = 6 marks)



- 12 A teacher carried out a demonstration using microwaves with a wavelength of 3.0 cm.
- (a) The microwaves were directed towards a gap of about 3 cm between two aluminium plates as shown. Microwaves were detected at point X.

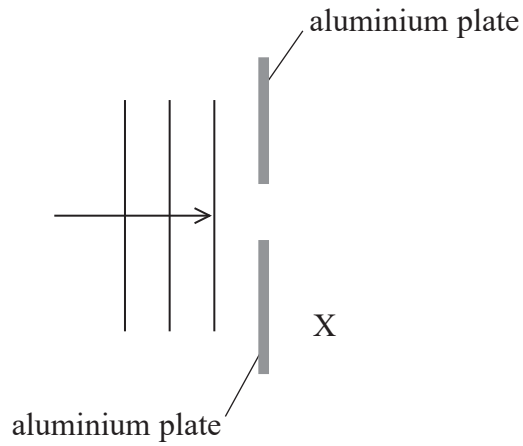

Explain why microwaves were detected at point X.

(2)

DO NOT WRITE IN THIS AREA

DO NOT WRITE IN THIS AREA

DO NOT WRITE IN THIS AREA



DO NOT WRITE IN THIS AREA

DO NOT WRITE IN THIS AREA

DO NOT WRITE IN THIS AREA

(b) An extra aluminium plate was added, so the microwaves were now incident on two gaps as shown.

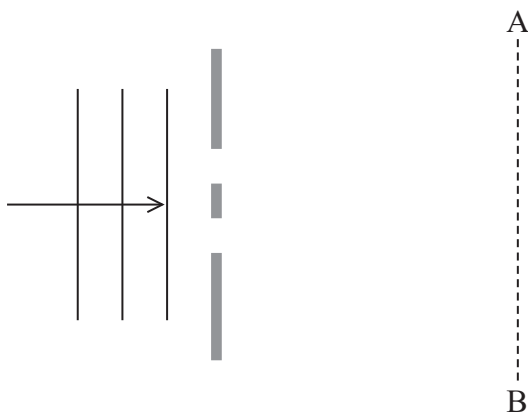

A microwave detector was moved along the line AB. Variations in intensity were detected.

Explain why several points of maximum intensity and minimum intensity were detected along the line AB.

(5)

.....

.....

.....

.....

.....

.....

.....

.....

.....

.....

.....

.....

.....

.....

.....

.....

.....

.....

.....

.....

.....

.....

.....

(Total for Question 12 = 7 marks)



- 13 The photoelectric effect occurs when electromagnetic radiation of a suitable frequency is incident on a metal plate. Observations of the photoelectric effect provide evidence in support of the particle model of light.

A zinc plate is illuminated with radiation of varying frequency f . The graph shows how the maximum kinetic energy E_{max} of the emitted electrons varies with f .

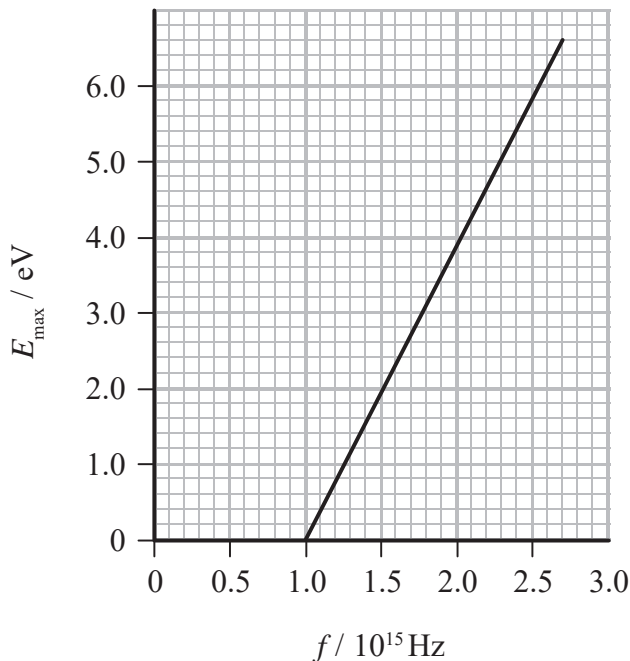

- (a) The frequency at which the line crosses the x -axis is known as the threshold frequency.
 (i) State what is meant by the threshold frequency.

(1)

DO NOT WRITE IN THIS AREA

DO NOT WRITE IN THIS AREA

DO NOT WRITE IN THIS AREA



- * (ii) Explain how the existence of a threshold frequency supports the particle theory of light and not the wave theory of light.

(4)

- (b) Radiation with a frequency of 2.4×10^{15} Hz is incident on the zinc plate.

Determine the maximum speed of the emitted electrons.

(4)

Maximum speed of emitted electrons =

(Total for Question 13 = 9 marks)

DO NOT WRITE IN THIS AREA

DO NOT WRITE IN THIS AREA

DO NOT WRITE IN THIS AREA



P 5 1 6 3 0 A 0 1 3 2 8

- 14 A string is fixed at both ends and held under tension. When the string is plucked at its midpoint a standing wave is formed on the string. The photograph shows the string vibrating at its fundamental frequency.



- (a) Explain how a standing wave is produced from travelling waves.

(3)

.....

.....

.....

.....

.....

.....

DO NOT WRITE IN THIS AREA

DO NOT WRITE IN THIS AREA

DO NOT WRITE IN THIS AREA



(b) The graph shows how the displacement of the midpoint of the string varies with time as the string vibrates at its fundamental frequency.

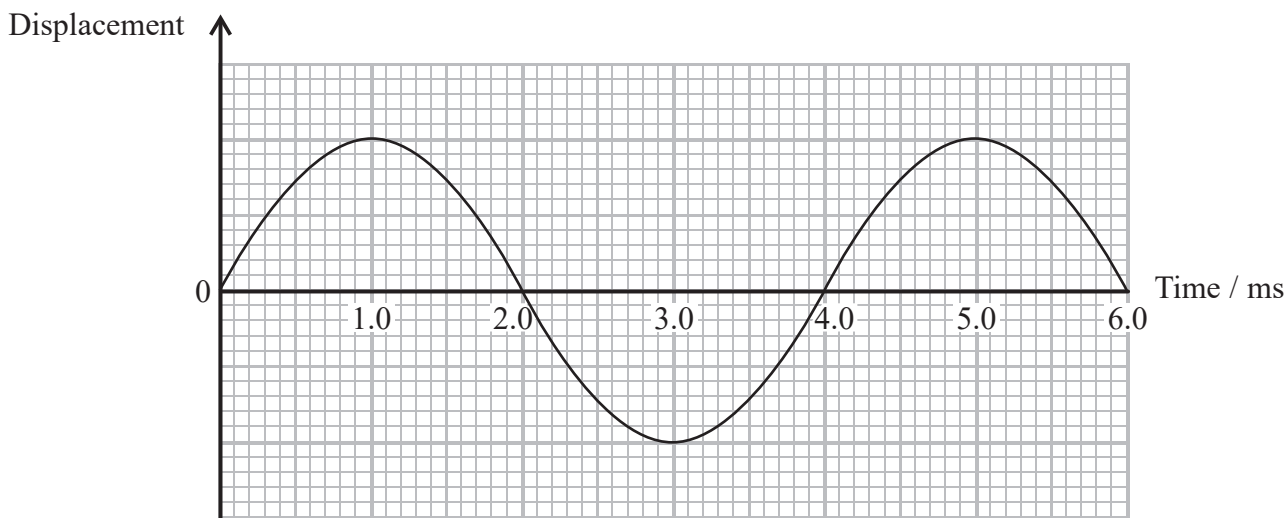

Calculate the length of the string.

(5)

speed of wave on string = 380 m s^{-1}

.....

.....

.....

.....

.....

.....

.....

.....

Length of the string =

(Total for Question 14 = 8 marks)

DO NOT WRITE IN THIS AREA

DO NOT WRITE IN THIS AREA

DO NOT WRITE IN THIS AREA



DO NOT WRITE IN THIS AREA

DO NOT WRITE IN THIS AREA

DO NOT WRITE IN THIS AREA

BLANK PAGE



DO NOT WRITE IN THIS AREA

DO NOT WRITE IN THIS AREA

DO NOT WRITE IN THIS AREA

15 The photograph shows a speed gun used to measure the speed of cars.



The speed gun emits pulses of infrared radiation every 0.250 s. The pulses are reflected by a moving car and then detected by the speed gun, which calculates and displays the speed of the car.

- (a) The speed gun was pointed at a moving car. One pulse was detected 533 ns after being emitted. The next pulse was detected 571 ns after being emitted.

Calculate the speed of the car.

(4)

.....

.....

.....

.....

.....

.....

.....

.....

.....

.....

Speed of car =

- (b) Explain why there is a maximum distance at which the speed gun is effective at measuring the speed of the car.

(2)

.....

.....

.....

.....

.....

.....

(Total for Question 15 = 6 marks)



16 A student used an ohmmeter to measure the resistance of different lengths of a wire.

The student plotted his results on a graph.

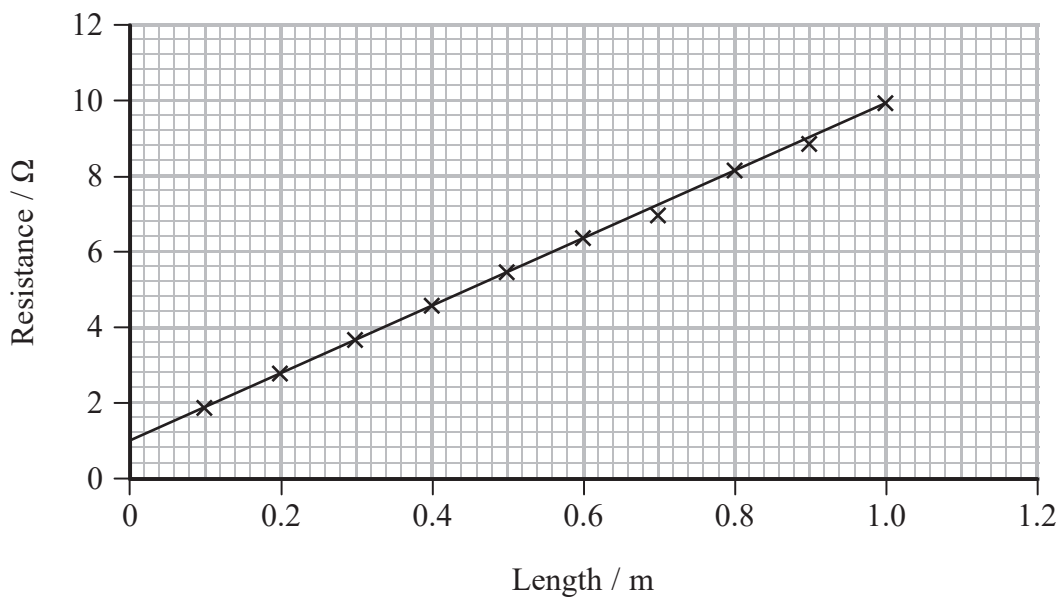

(a) Explain, in terms of conduction electrons, why the resistance increases with the length of the wire.

(3)

.....

.....

.....

.....

.....

.....

.....

(b) Describe how the student should measure the diameter of the wire as accurately as possible.

(3)

.....

.....

.....

.....

.....

DO NOT WRITE IN THIS AREA

DO NOT WRITE IN THIS AREA

DO NOT WRITE IN THIS AREA



(c) Determine the resistivity of the wire.

(3)

cross-sectional area of the wire = $1.3 \times 10^{-7} \text{ m}^2$

Resistivity =

(d) Due to a systematic error the student's graph does not go through the origin.

Suggest the source of the systematic error.

(1)

(Total for Question 16 = 10 marks)

DO NOT WRITE IN THIS AREA

DO NOT WRITE IN THIS AREA

DO NOT WRITE IN THIS AREA



17 The refractive index of a drink can be used to determine the percentage of sugar in the drink.

The graph shows how the refractive index of a drink varies with the percentage of sugar in the drink.

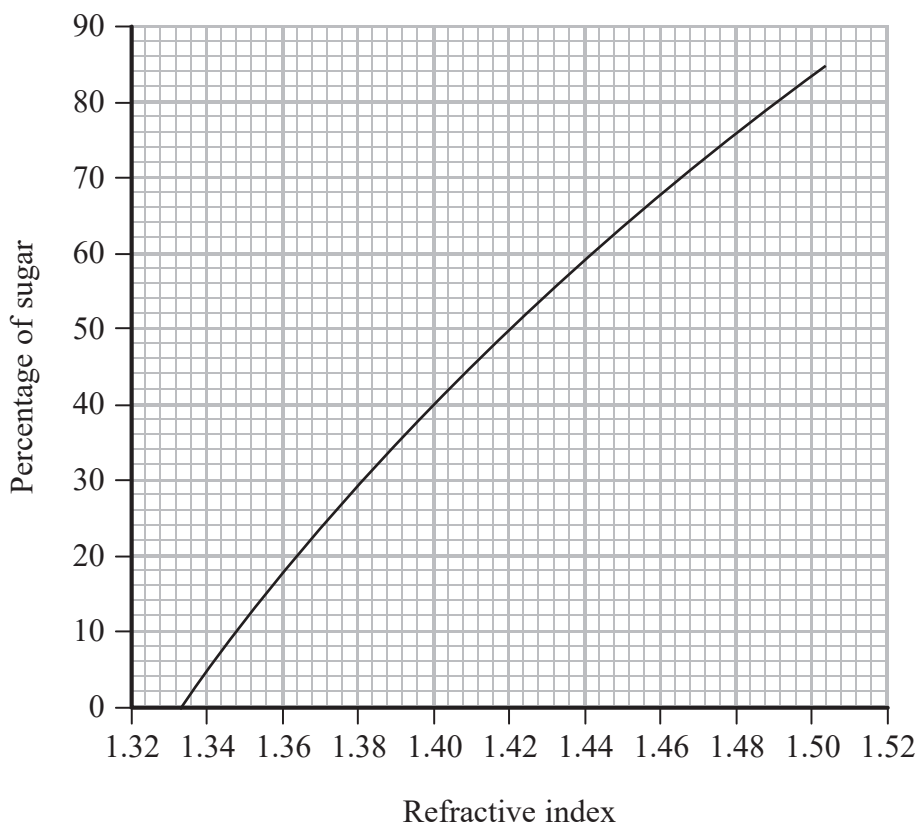

(a) The drink is poured into a container with thin Perspex walls. A laser is used to shine a ray of light through the drink. The diagram shows the arrangement viewed from above.

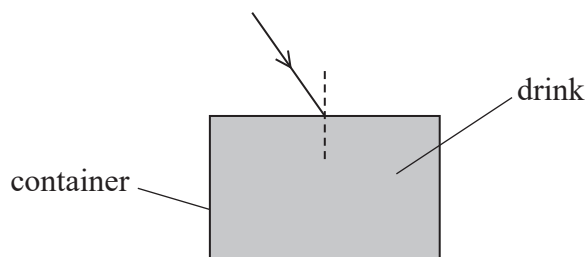

(i) Explain how the percentage of sugar in the drink affects the path of the ray as it enters the drink.

(2)

.....

.....

.....

.....

DO NOT WRITE IN THIS AREA

DO NOT WRITE IN THIS AREA

DO NOT WRITE IN THIS AREA



- (ii) The angle of incidence and the angle of refraction of the light ray as it passes into the drink are measured.

Determine the percentage of sugar in the drink. You can ignore the effect of the light ray passing through the Perspex.

(3)

angle of incidence = 40°

angle of refraction = 26°

.....

.....

.....

.....

.....

.....

Percentage of sugar =

DO NOT WRITE IN THIS AREA

DO NOT WRITE IN THIS AREA

DO NOT WRITE IN THIS AREA



DO NOT WRITE IN THIS AREA

DO NOT WRITE IN THIS AREA

DO NOT WRITE IN THIS AREA

- (b) An alternative method to determine the percentage of sugar in a drink is shown. As polarised light passes through the drink, the plane of polarisation rotates by an amount dependent on the percentage of sugar in the drink.

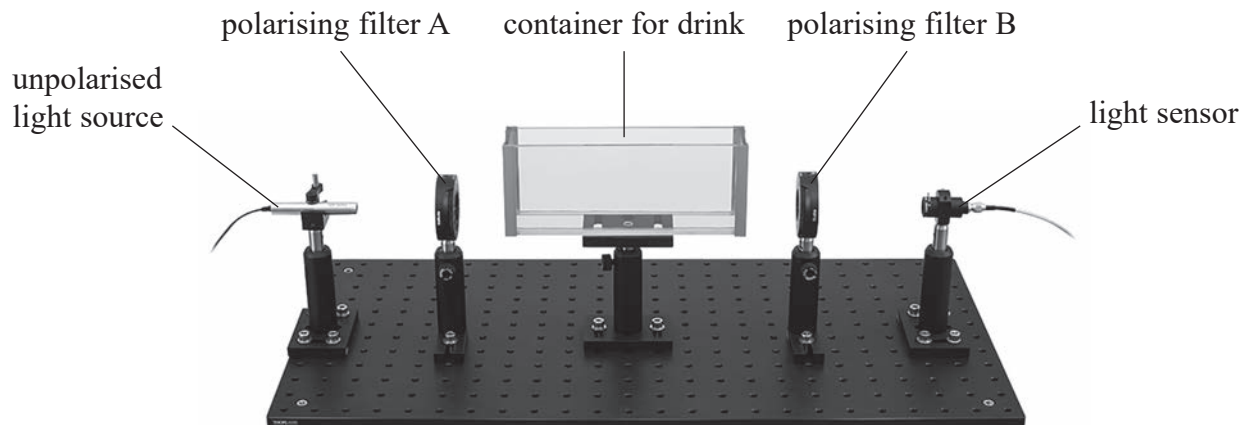

- (i) Explain what is meant by the plane of polarisation.

(2)

.....

.....

.....

.....

- (ii) Initially there is no drink in the container and the polarising filters are aligned so that no light is detected by the light sensor.

Explain how the alignment of the two polarising filters, A and B, ensures that no light is detected.

(2)

.....

.....

.....

.....

.....



- (iii) The polarising filters are kept in alignment so no light is detected. Then the container is filled with drink and light is detected.

Explain why the intensity of the light detected is less than the intensity of the light transmitted by polarising filter A.

(2)

- (iv) Explain how the angle through which the plane of polarisation has been rotated can be determined using this apparatus.

(3)

(Total for Question 17 = 14 marks)

DO NOT WRITE IN THIS AREA

DO NOT WRITE IN THIS AREA

DO NOT WRITE IN THIS AREA



- 18 The Aurora Borealis (northern lights) and Aurora Australis (southern lights) occur when charged particles emitted by the Sun are deflected by the Earth's magnetic field. As the particles travel through the Earth's atmosphere they collide with the atoms in the air, resulting in the production of streaks of light. The photograph shows the streaks of light that can be observed across the sky, close to the North Pole and the South Pole.



- *(a) Explain how light is emitted due to collisions between charged particles and the atoms of the gases in the air.

(5)

DO NOT WRITE IN THIS AREA

DO NOT WRITE IN THIS AREA

DO NOT WRITE IN THIS AREA



DO NOT WRITE IN THIS AREA

DO NOT WRITE IN THIS AREA

DO NOT WRITE IN THIS AREA

(b) The green colour commonly observed in an aurora is caused when the charged particles collide with oxygen atoms.
The intensity of the green light depends on the number of charged particles and the number of oxygen atoms.

Explain why.

(2)

.....

.....

.....

.....

(c) Scientists have observed the light emitted from aurorae on other planets.

Explain how these observations give information about the gases surrounding other planets.

(3)

.....

.....

.....

.....

.....

.....

.....

(Total for Question 18 = 10 marks)

TOTAL FOR SECTION B = 70 MARKS

TOTAL FOR PAPER = 80 MARKS



DO NOT WRITE IN THIS AREA

DO NOT WRITE IN THIS AREA

DO NOT WRITE IN THIS AREA

BLANK PAGE



List of data, formulae and relationships

Acceleration of free fall	$g = 9.81 \text{ m s}^{-2}$	(close to Earth's surface)
Electron charge	$e = -1.60 \times 10^{-19} \text{ C}$	
Electron mass	$m_e = 9.11 \times 10^{-31} \text{ kg}$	
Electronvolt	$1 \text{ eV} = 1.60 \times 10^{-19} \text{ J}$	
Gravitational field strength	$g = 9.81 \text{ N kg}^{-1}$	(close to Earth's surface)
Planck constant	$h = 6.63 \times 10^{-34} \text{ J s}$	
Speed of light in a vacuum	$c = 3.00 \times 10^8 \text{ m s}^{-1}$	

Unit 1

Mechanics

Kinematic equations of motion	$v = u + at$
	$s = ut + \frac{1}{2}at^2$
	$v^2 = u^2 + 2as$

Forces	$\Sigma F = ma$
	$g = F/m$
	$W = mg$

Work and energy	$\Delta W = F\Delta s$
	$E_k = \frac{1}{2}mv^2$
	$\Delta E_{\text{grav}} = mg\Delta h$

Materials

Stokes' law	$F = 6\pi\eta rv$
-------------	-------------------

Hooke's law	$F = k\Delta x$
-------------	-----------------

Density	$\rho = m/V$
---------	--------------

Pressure	$p = F/A$
----------	-----------

Young modulus	$E = \sigma/\epsilon$ where
	Stress $\sigma = F/A$
	Strain $\epsilon = \Delta x/x$

Elastic strain energy	$E_{\text{el}} = \frac{1}{2}F\Delta x$
-----------------------	--



Unit 2**Waves**

Wave speed

$$v = f\lambda$$

Refractive index

$${}_1\mu_2 = \sin i / \sin r = v_1 / v_2$$

Electricity

Potential difference

$$V = W/Q$$

Resistance

$$R = V/I$$

Electrical power, energy and efficiency

$$P = VI$$

$$P = I^2R$$

$$P = V^2/R$$

$$W = VI t$$

$$\% \text{ efficiency} = \frac{\text{useful energy output}}{\text{total energy input}} \times 100$$

$$\% \text{ efficiency} = \frac{\text{useful power output}}{\text{total power input}} \times 100$$

Resistivity

$$R = \rho l/A$$

Current

$$I = \Delta Q / \Delta t$$

$$I = nqvA$$

Resistors in series

$$R = R_1 + R_2 + R_3$$

Resistors in parallel

$$\frac{1}{R} = \frac{1}{R_1} + \frac{1}{R_2} + \frac{1}{R_3}$$

Quantum physics

Photon model

$$E = hf$$

Einstein's photoelectric equation

$$hf = \phi + \frac{1}{2}mv_{\max}^2$$

DO NOT WRITE IN THIS AREA

DO NOT WRITE IN THIS AREA

DO NOT WRITE IN THIS AREA

