

Please check the examination details below before entering your candidate information

Candidates surname					Other names				
Centre Number				Candidate Number					
<input type="text"/>	<input type="text"/>	<input type="text"/>	<input type="text"/>	<input type="text"/>	<input type="text"/>	<input type="text"/>	<input type="text"/>	<input type="text"/>	<input type="text"/>

Pearson Edexcel International Advanced Level

Time 1 hour 30 minutes

Paper reference **WPH11/01**

Physics

International Advanced Subsidiary/Advanced Level

UNIT 1: Mechanics and Materials

You must have:
Scientific calculator, ruler

Total Marks

Instructions

- Use **black** ink or ball-point pen.
- If pencil is used for diagrams/sketches/graphs it must be dark (HB or B).
- **Fill in the boxes** at the top of this page with your name, centre number and candidate number.
- Answer **all** questions.
- Answer the questions in the spaces provided
– *there may be more space than you need.*
- **Show all your working out** in calculations and **include units** where appropriate.

Information

- The total mark for this paper is 80.
- The marks for **each** question are shown in brackets
– *use this as a guide as to how much time to spend on each question.*
- In the question marked with an **asterisk (*)**, marks will be awarded for your ability to structure your answers logically, showing how the points that you make are related or follow on from each other where appropriate.
- The list of data, formulae and relationships is printed at the end of this booklet.

Advice

- Read each question carefully before you start to answer it.
- Try to answer every question.
- Check your answers if you have time at the end.

Turn over ►

P71878A

©2022 Pearson Education Ltd.

B:1/1/1/



Pearson

SECTION A**Answer ALL questions.**

For questions 1–10, in Section A, select one answer from A to D and put a cross in the box ☒. If you change your mind, put a line through the box ☒ and then mark your new answer with a cross ☒.

1 Which of the following quantities is given by the area under a velocity-time graph?

- A acceleration
- B displacement
- C speed
- D time taken

(Total for Question 1 = 1 mark)

2 Which of the following quantities is a vector?

- A energy
- B mass
- C momentum
- D power

(Total for Question 2 = 1 mark)

3 Which of the following best describes the situations in which Stokes' Law applies for objects moving in a fluid?

- A all spherical objects moving at low speeds
- B all spherical objects in a fluid with low viscosity
- C small spherical objects moving at low speeds
- D small spherical objects in a fluid with low viscosity

(Total for Question 3 = 1 mark)

DO NOT WRITE IN THIS AREA

DO NOT WRITE IN THIS AREA

DO NOT WRITE IN THIS AREA



- 4 A car accelerated along a straight road. The graph shows how the acceleration of the car varied with time.

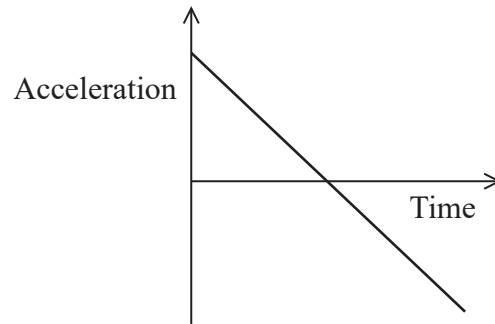

Which of the following graphs shows how the velocity of the car varied with time over the same time interval?

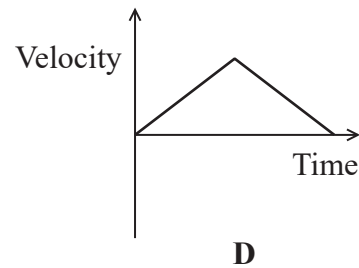
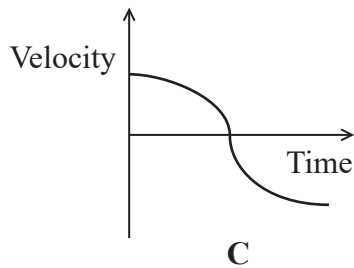
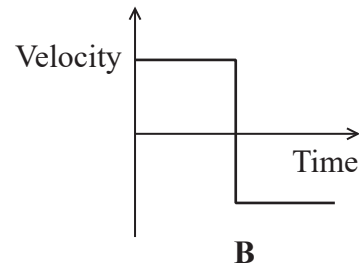
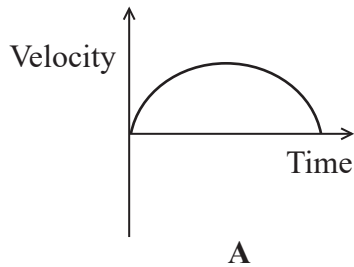

- A
- B
- C
- D

(Total for Question 4 = 1 mark)



- 5 A sample of a material is in the form of a wire. The material has a large value of the Young modulus.

Which of the following statements best describes the material?

- A A large force per unit cross-sectional area is required to break the wire.
- B The mass per unit volume is large.
- C The ratio of tensile stress to tensile strain is large.
- D After removing a large stress the sample returns to its original length.

(Total for Question 5 = 1 mark)

- 6 A rubber band is initially stretched by an increasing force. When the force is gradually decreased, the rubber band returns to its original length.

The force-extension graph for the rubber band is shown.

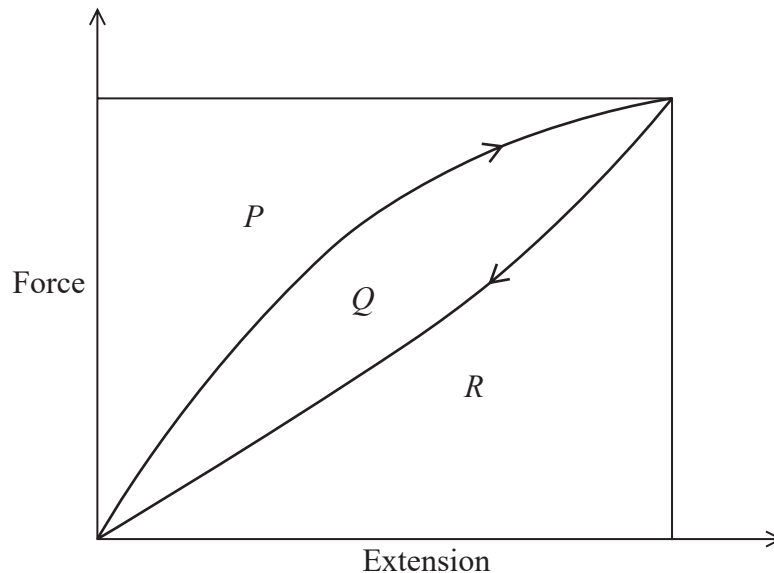

P , Q and R represent different areas of the graph.

Which of the following gives the work done in stretching the rubber band up to its maximum extension?

- A $P + Q$
- B $Q + R$
- C R
- D Q

(Total for Question 6 = 1 mark)



7 Two forces, X and Y, act at a point.

Which of the following vector diagrams shows the magnitude and direction of the resultant of the two forces?

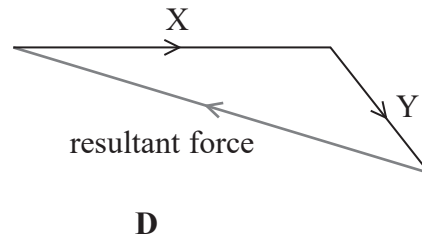
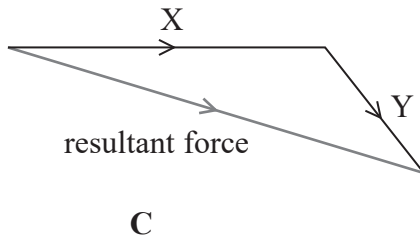
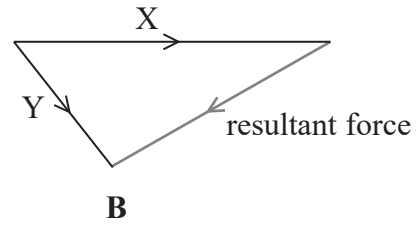
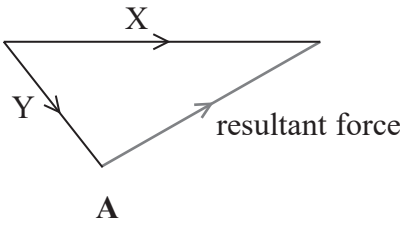

- A
- B
- C
- D

(Total for Question 7 = 1 mark)



- 8 When a certain spring is stretched by a tensile force F , the elastic energy stored in the spring is E .

Three of these springs are arranged in parallel and stretched by a tensile force of $2F$, as shown.

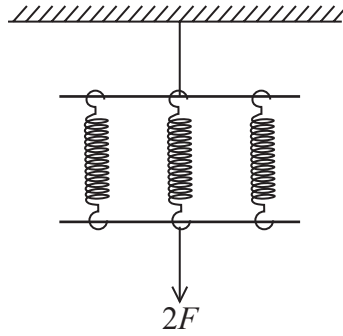

Which of the following expressions gives the elastic energy stored in the parallel system?

- A $\frac{1}{3}E$
- B $\frac{2}{3}E$
- C $\frac{4}{3}E$
- D $2E$

(Total for Question 8 = 1 mark)

DO NOT WRITE IN THIS AREA

DO NOT WRITE IN THIS AREA

DO NOT WRITE IN THIS AREA



- 9 A proton and an electron have equal kinetic energies. The speed of the proton is v .
The mass of a proton is 2000 times greater than the mass of an electron.
Which of the following expressions gives the speed of the electron?

- A $\sqrt{2000} \times v$
- B $\frac{v}{\sqrt{2000}}$
- C $\frac{v}{2000}$
- D $2000 \times v$

(Total for Question 9 = 1 mark)

- 10 An electric pump has an output power of 25 kW and an efficiency of 52%.
Which of the following expressions gives the rate in kW at which energy is dissipated?

- A 0.48×25
- B 0.52×25
- C $\frac{0.48 \times 25}{0.52}$
- D $\frac{25}{0.52}$

(Total for Question 10 = 1 mark)

TOTAL FOR SECTION A = 10 MARKS

DO NOT WRITE IN THIS AREA

DO NOT WRITE IN THIS AREA

DO NOT WRITE IN THIS AREA



SECTION B

Answer ALL questions in the spaces provided.

- 11 The engine of a motor boat provides a constant horizontal force. As the velocity of the boat increases, the resultant horizontal force on the boat decreases. Eventually the boat will travel at its terminal velocity.

The constant horizontal force from the engine is 5.5 kN.

- (a) State what is meant by a resultant force.

(1)

- (b) At a certain time the drag force on the boat is 3.1 kN.

Calculate the acceleration of the boat at this time.

mass of boat = 7.5×10^3 kg

(2)

Acceleration =

- (c) The terminal velocity of the boat is 4.8 m s^{-1} .

Calculate the output power of the engine.

(2)

Output power =

(Total for Question 11 = 5 marks)

DO NOT WRITE IN THIS AREA

DO NOT WRITE IN THIS AREA

DO NOT WRITE IN THIS AREA



DO NOT WRITE IN THIS AREA

DO NOT WRITE IN THIS AREA

DO NOT WRITE IN THIS AREA

BLANK PAGE



12 A student carried out an experiment to determine the Young modulus of constantan.

The student had a constantan wire with cross-sectional area A of $3.97 \times 10^{-7} \text{ m}^2$.

The unstretched length x of the wire was 4.00 m.

(a) The student had enough slotted masses to apply a weight of up to 150 N to the wire.

The breaking stress for constantan is about 420 MPa.

Deduce whether the wire could support a weight of 150 N.

(3)

(b) The student added slotted masses to the wire and determined the corresponding extensions. The student plotted a graph of force against extension, as shown.

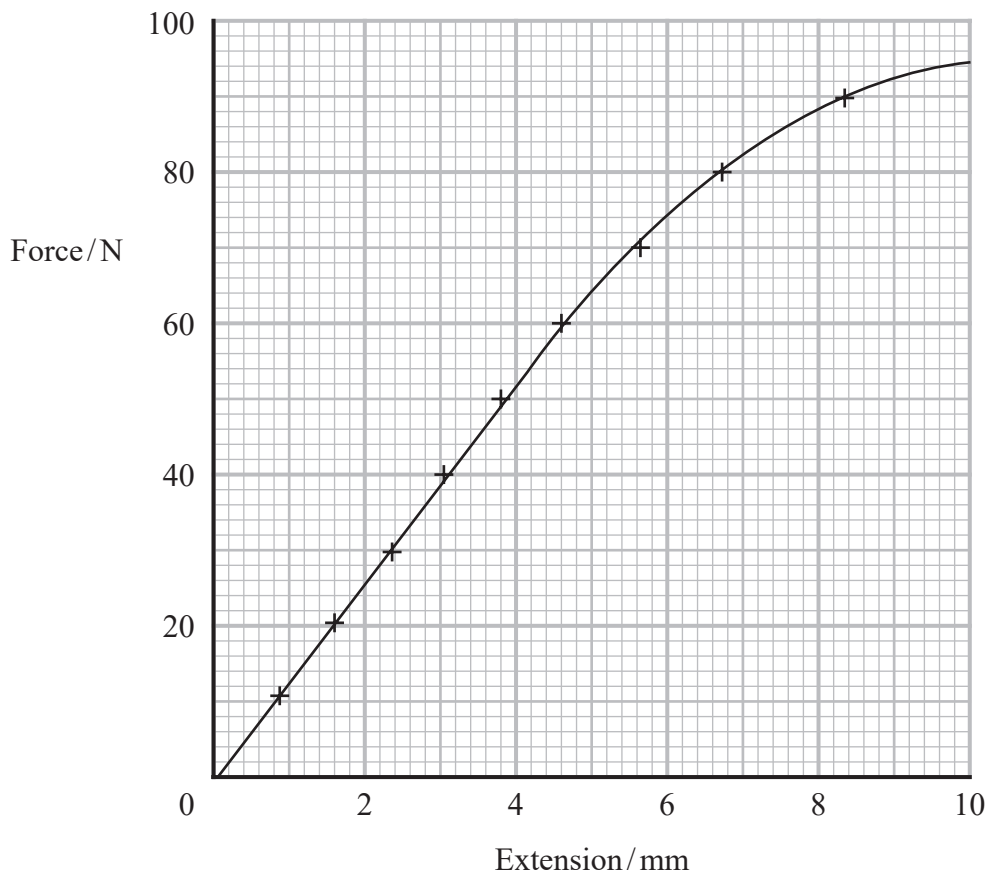

DO NOT WRITE IN THIS AREA

DO NOT WRITE IN THIS AREA

DO NOT WRITE IN THIS AREA



- (i) Show that the stiffness of the wire is about $1.3 \times 10^4 \text{ N m}^{-1}$.

(2)

- (ii) The relationship between the stiffness k of the wire and the Young modulus E is given by

$$k = \frac{EA}{x}$$

where x is the unstretched length of the wire and A is the cross-sectional area of the wire.

Determine a value for the Young modulus of constantan using the student's data.

(2)

Young modulus =

(Total for Question 12 = 7 marks)

DO NOT WRITE IN THIS AREA

DO NOT WRITE IN THIS AREA

DO NOT WRITE IN THIS AREA



P 7 1 8 7 8 A 0 1 1 2 8

- 13 A woman supports a stationary wheelbarrow by exerting an upward force P on the handles. An upward force R from the ground acts on the wheel, as shown.

The centre of gravity G of the wheelbarrow is marked on the diagram.



(Source: © Cavan Images/Alamy Stock Photo)

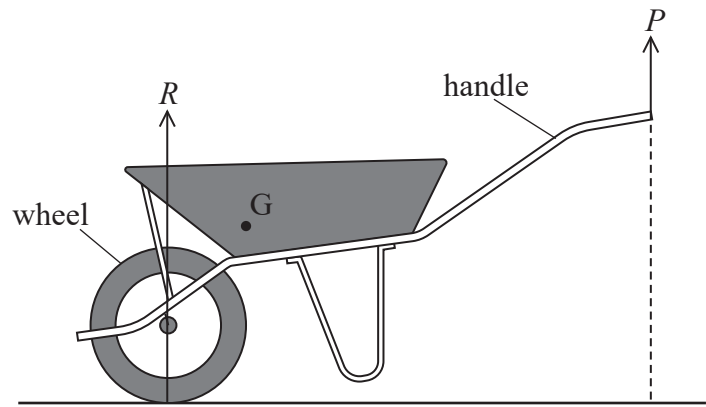

- (a) Explain, by considering moments about G , why P is less than R .

(3)

.....

.....

.....

.....

.....

.....

DO NOT WRITE IN THIS AREA

DO NOT WRITE IN THIS AREA

DO NOT WRITE IN THIS AREA



- (b) The horizontal distance between the centre of the wheel and the handles is 1.5 m.
The magnitudes of P and R are as shown.

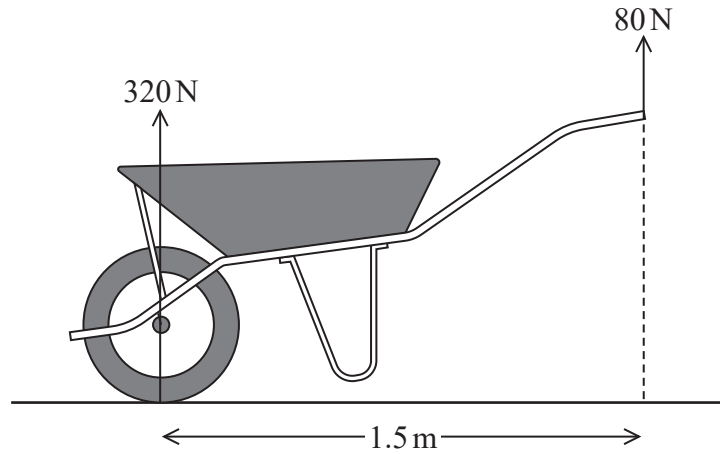

Determine the horizontal distance between the centre of gravity of the wheelbarrow and the centre of the wheel.

(4)

Horizontal distance =

(Total for Question 13 = 7 marks)



- 14 A child is holding a balloon by a string, as shown. The balloon contains helium gas. Helium gas is less dense than air.

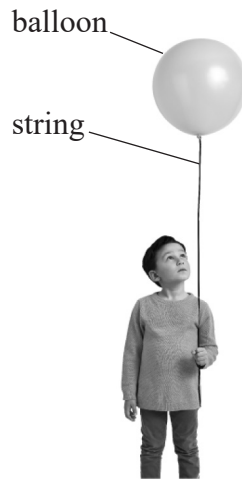

(Source: © pinstock/Getty Images)

- (a) The child releases the balloon by letting go of the string.

Calculate the resultant force on the balloon immediately after it is released.

$$\text{mass of balloon and string} = 9.20 \times 10^{-3} \text{ kg}$$

$$\text{volume of balloon and string} = 5.00 \times 10^{-2} \text{ m}^3$$

$$\text{density of air} = 1.20 \text{ kg m}^{-3}$$

(4)

Resultant force =

DO NOT WRITE IN THIS AREA

DO NOT WRITE IN THIS AREA

DO NOT WRITE IN THIS AREA



- 15 A boy was throwing a ball towards a wall. The wall was 5.00 m from the boy. The top of the wall was 3.00 m above the point where the boy released the ball.

The boy tried to throw the ball over the wall but sometimes the ball hit the wall.

In one attempt, the boy threw the ball with an initial velocity of 9.70 m s^{-1} at an angle to the horizontal of 49.0° , as shown.

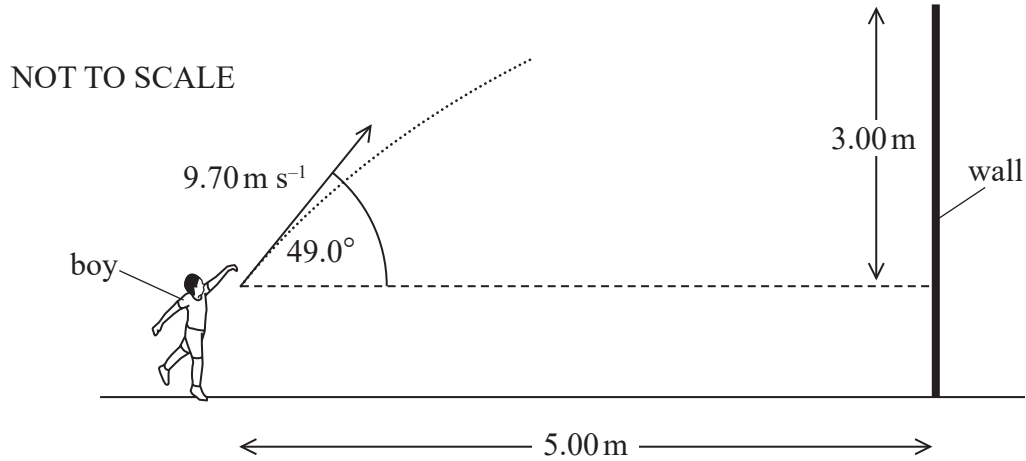

- (a) Show that the ball travelled the distance to the wall in about 0.8 s.

(3)

.....

.....

.....

.....

.....

.....

.....

DO NOT WRITE IN THIS AREA

DO NOT WRITE IN THIS AREA

DO NOT WRITE IN THIS AREA



16 Speed skating on ice is an Olympic sport. Collisions between skaters sometimes occur.

(a) State the principle of conservation of momentum.

(2)

.....

.....

.....

.....

(b) Two speed skaters are skating as shown.

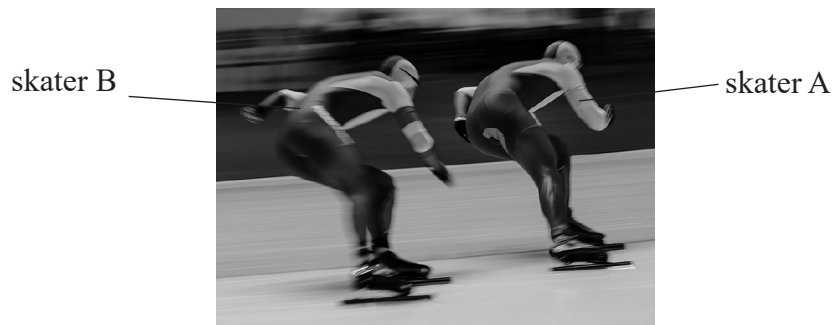

(Source: © sportpoint/Shutterstock)

Initially, skater B is directly behind skater A. Skater B is moving faster and collides with skater A.

During the collision, skater B locks his arms around skater A so that they move forward together with a speed of 6.2 m s^{-1} .

Deduce whether momentum is conserved in this collision.

initial speed of skater A = 5.5 m s^{-1}

mass of skater A = 65 kg

initial speed of skater B = 7.5 m s^{-1}

mass of skater B = 60 kg

(3)

.....

.....

.....

.....

.....

.....

.....

.....

.....



17 Foraminifera, known as ‘forams’, are small sea creatures with shells.

- (a) When forams die they sink slowly through the seawater to form a layer at the bottom of the sea. The photograph shows a magnified view of some typical forams.

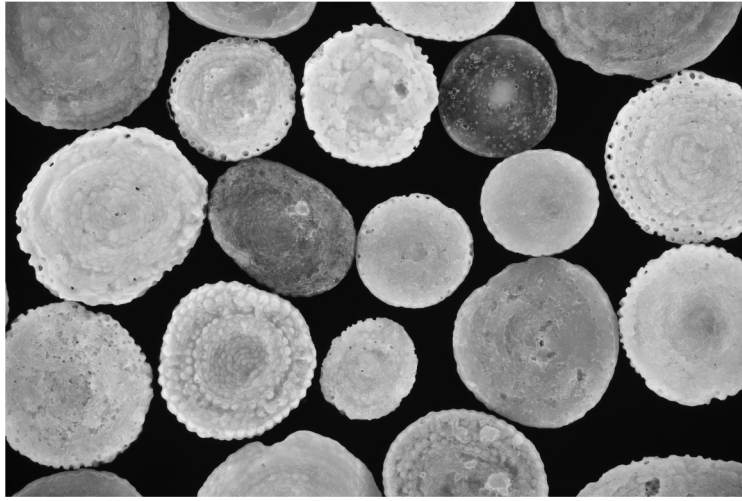

(Source: © alex7370/Shutterstock)

- (i) A spherical foram with a mass of 1.15×10^{-8} kg is sinking at terminal velocity in seawater. The upthrust due to the seawater is 4.37×10^{-8} N. The flow of seawater around the sinking foram is laminar.

Show that the viscous drag on the foram is about 7×10^{-8} N.

(3)

.....

.....

.....

.....

.....

.....

.....

DO NOT WRITE IN THIS AREA

DO NOT WRITE IN THIS AREA

DO NOT WRITE IN THIS AREA



(ii) Calculate the terminal velocity of this foram.

diameter of foram = 9.2×10^{-4} m

viscosity of seawater = 1.41×10^{-3} Pa s

(2)

Terminal velocity =

(b) As the forams sink deeper into the sea, the temperature of the water becomes lower.

Discuss how the terminal velocities of forams change as they sink deeper into the sea.

(4)

(Total for Question 17 = 9 marks)

DO NOT WRITE IN THIS AREA

DO NOT WRITE IN THIS AREA

DO NOT WRITE IN THIS AREA



P 7 1 8 7 8 A 0 2 1 2 8

- 18 A railway engine is pushing a truck along horizontal rails at a constant velocity, as shown.

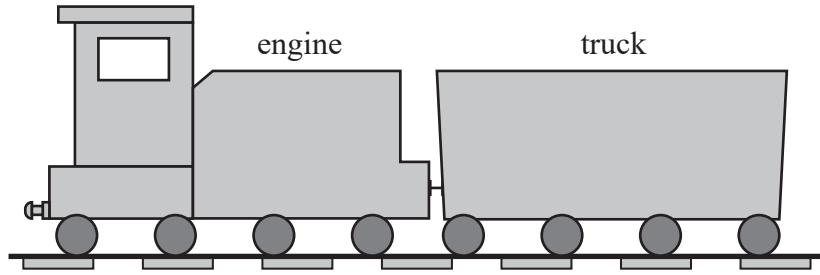

The engine exerts a forward force of $1.2 \times 10^5 \text{ N}$ on the truck. The engine also exerts a net backwards force of $1.5 \times 10^5 \text{ N}$ on the rails.

- (a) Complete the free-body force diagram to show all the forces acting on the engine.

(4)

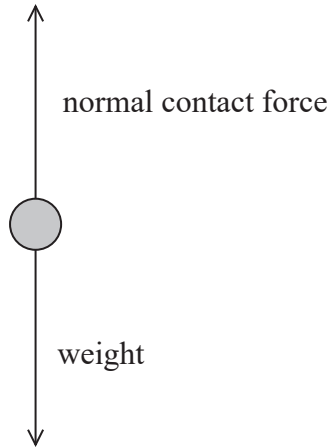

DO NOT WRITE IN THIS AREA

DO NOT WRITE IN THIS AREA

DO NOT WRITE IN THIS AREA



(b) A student suggests that the weight and the normal reaction force form a Newton's third law pair of forces.

Explain why the student's suggestion is **not** correct. Your answer should include reference to the features of a Newton's third law pair of forces.

(5)

.....

.....

.....

.....

.....

.....

.....

.....

.....

.....

.....

.....

.....

.....

.....

.....

.....

.....

.....

.....

.....

.....

(Total for Question 18 = 9 marks)

DO NOT WRITE IN THIS AREA

DO NOT WRITE IN THIS AREA

DO NOT WRITE IN THIS AREA



- 19 A cyclist is moving up a slope at a constant speed. The angle of the slope to the horizontal is 4.0° , as shown.

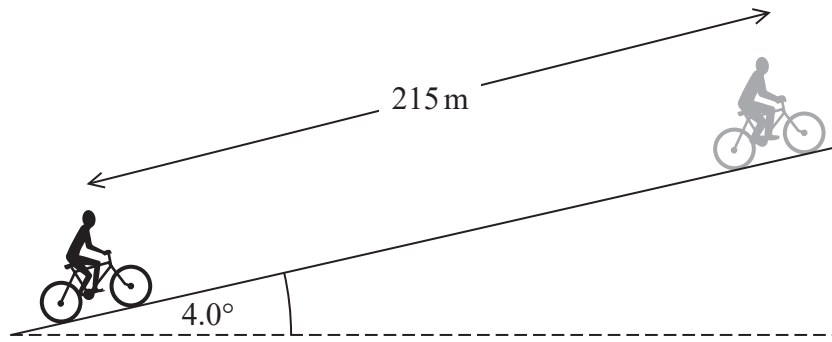

As the cyclist pedals, there is a constant forward force on the bicycle of 150 N. The cyclist travels 215 m along the slope.

- (a) Show that the work done by the cyclist is about 3×10^4 J.

(2)

- (b) The cyclist must do work against the force of gravity and air resistance.

- (i) Calculate the work done by the cyclist against air resistance.

mass of cyclist and bicycle = 90 kg

(4)

Work done against air resistance =

DO NOT WRITE IN THIS AREA

DO NOT WRITE IN THIS AREA

DO NOT WRITE IN THIS AREA



- (ii) State one assumption that must be made when calculating the work done against air resistance.

(1)

- (c) At the top of the slope, the road becomes horizontal. The cyclist continues to pedal with the same force.

Explain how the speed of the cyclist changes as the road becomes horizontal.

(2)

(Total for Question 19 = 9 marks)

TOTAL FOR SECTION B = 70 MARKS

TOTAL FOR PAPER = 80 MARKS

DO NOT WRITE IN THIS AREA

DO NOT WRITE IN THIS AREA

DO NOT WRITE IN THIS AREA



P 7 1 8 7 8 A 0 2 5 2 8

List of data, formulae and relationships

Acceleration of free fall	$g = 9.81 \text{ m s}^{-2}$	(close to Earth's surface)
Gravitational field strength	$g = 9.81 \text{ N kg}^{-1}$	(close to Earth's surface)

Unit 1

Mechanics

Kinematic equations of motion	$s = \frac{(u + v)t}{2}$
	$v = u + at$
	$s = ut + \frac{1}{2}at^2$
	$v^2 = u^2 + 2as$

Forces	$\Sigma F = ma$
	$g = \frac{F}{m}$
	$W = mg$

Momentum	$p = mv$
----------	----------

Moment of force	moment = Fx
-----------------	---------------

Work and energy	$\Delta W = F\Delta s$
-----------------	------------------------

$$E_k = \frac{1}{2}mv^2$$

$$\Delta E_{\text{grav}} = mg\Delta h$$

Power	$P = \frac{E}{t}$
	$P = \frac{W}{t}$

Efficiency	efficiency = $\frac{\text{useful energy output}}{\text{total energy input}}$
	efficiency = $\frac{\text{useful power output}}{\text{total power input}}$

Materials

Density	$\rho = \frac{m}{V}$
---------	----------------------

Stokes' law	$F = 6\pi\eta rv$
-------------	-------------------

Hooke's law	$\Delta F = k\Delta x$
-------------	------------------------

Elastic strain energy	$\Delta E_{\text{el}} = \frac{1}{2}F\Delta x$
-----------------------	---

Young modulus	$E = \frac{\sigma}{\epsilon}$ where
---------------	-------------------------------------

$$\text{Stress } \sigma = \frac{F}{A}$$

$$\text{Strain } \epsilon = \frac{\Delta x}{x}$$

DO NOT WRITE IN THIS AREA

DO NOT WRITE IN THIS AREA

DO NOT WRITE IN THIS AREA



DO NOT WRITE IN THIS AREA

DO NOT WRITE IN THIS AREA

DO NOT WRITE IN THIS AREA

BLANK PAGE



P 7 1 8 7 8 A 0 2 7 2 8

DO NOT WRITE IN THIS AREA

DO NOT WRITE IN THIS AREA

DO NOT WRITE IN THIS AREA

BLANK PAGE

