

Please check the examination details below before entering your candidate information

Candidates surname					Other names				
Centre Number					Candidate Number				
<input type="text"/>	<input type="text"/>	<input type="text"/>	<input type="text"/>	<input type="text"/>	<input type="text"/>	<input type="text"/>	<input type="text"/>	<input type="text"/>	<input type="text"/>

**Pearson Edexcel International Advanced Level**

Time 1 hour 30 minutes

Paper reference **WPH12/01**

**Physics**

**International Advanced Subsidiary/Advanced Level**

**UNIT 2: Waves and Electricity**

**You must have:**  
Scientific calculator, ruler, protractor

Total Marks

### Instructions

- Use **black** ink or ball-point pen.
- If pencil is used for diagrams/sketches/graphs it must be dark (HB or B).
- **Fill in the boxes** at the top of this page with your name, centre number and candidate number.
- Answer **all** questions.
- Answer the questions in the spaces provided  
– *there may be more space than you need.*
- **Show all your working out** in calculations and **include units** where appropriate.

### Information

- The total mark for this paper is 80.
- The marks for **each** question are shown in brackets  
– *use this as a guide as to how much time to spend on each question.*
- In the question marked with an **asterisk (\*)**, marks will be awarded for your ability to structure your answer logically, showing how the points that you make are related or follow on from each other where appropriate.
- The list of data, formulae and relationships is printed at the end of this booklet.

### Advice

- Read each question carefully before you start to answer it.
- Try to answer every question.
- Check your answers if you have time at the end.

Turn over ►

P71879A

©2022 Pearson Education Ltd.

B:1/1/



  
Pearson

## SECTION A

Answer ALL questions.

For questions 1–10, in Section A, select one answer from A to D and put a cross in the box . If you change your mind, put a line through the box  and then mark your new answer with a cross .

- 1 Which of the following pairs of quantities could be used to calculate the speed of a wave?

- A amplitude and frequency  
 B amplitude and wavelength  
 C period and frequency  
 D period and wavelength

(Total for Question 1 = 1 mark)

- 2 The diagram shows four possible transitions of electrons in an atom.

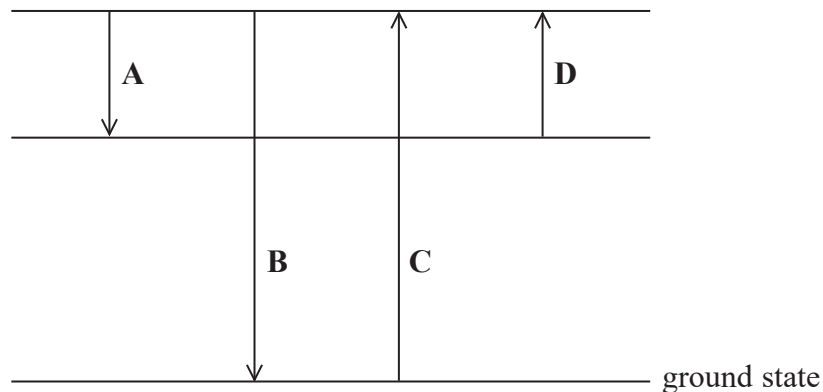

Which of the transitions will result in the emission of a photon with the longest wavelength?

- A  
 B  
 C  
 D

(Total for Question 2 = 1 mark)



- 3 A negative temperature coefficient thermistor and a fixed resistor are connected in a circuit, as shown.

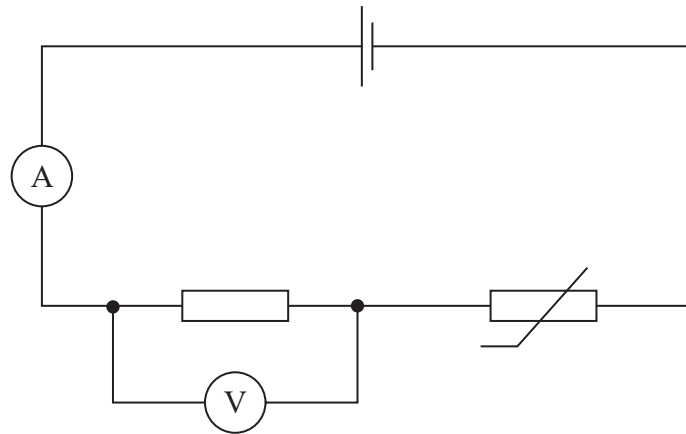

The temperature of the thermistor increases.

Which row of the table shows the changes to the ammeter and voltmeter readings as the temperature increases?

	Ammeter reading	Voltmeter reading
<input type="checkbox"/> A	decreases	decreases
<input type="checkbox"/> B	decreases	increases
<input type="checkbox"/> C	increases	decreases
<input type="checkbox"/> D	increases	increases

(Total for Question 3 = 1 mark)

- 4 Two students are discussing longitudinal waves.

**Student 1** states that at the centre of a compression the displacement of molecules is zero.

**Student 2** states that at the centre of a rarefaction the displacement of molecules is zero.

Which of the students' statements are correct?

- A Both
- B Neither
- C Only student 1
- D Only student 2

(Total for Question 4 = 1 mark)



5 The graphs show how current  $I$  varies with potential difference  $V$  for three components.

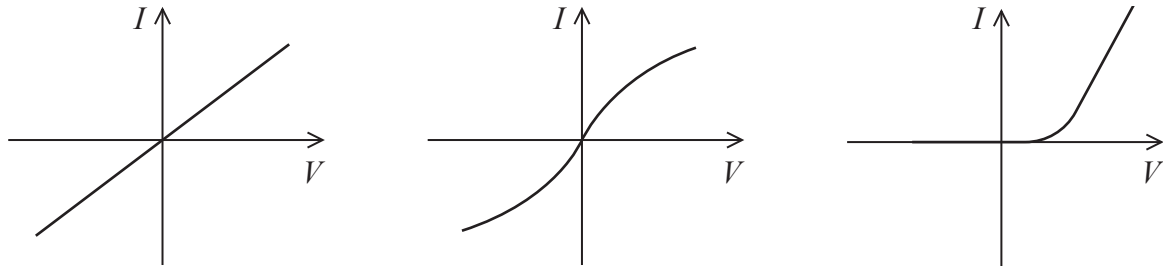

Which of the following components is **not** represented by any of the three graphs?

- A diode
- B filament bulb
- C negative temperature coefficient thermistor
- D ohmic conductor

(Total for Question 5 = 1 mark)

6 When the temperature of a metal wire increases, the resistance of the wire increases.

Which of the following explains this increase in resistance?

- A the amplitude of the lattice vibrations decreases
- B the amplitude of the lattice vibrations increases
- C the number of conduction electrons decreases
- D the number of conduction electrons increases

(Total for Question 6 = 1 mark)

DO NOT WRITE IN THIS AREA

DO NOT WRITE IN THIS AREA

DO NOT WRITE IN THIS AREA



7 The current at a point in a circuit is 1.25 A.

Which of the following expressions gives the number of electrons passing the point in 45 seconds?

- A  $\frac{1.25 \times 45}{1.60 \times 10^{-19}}$
- B  $\frac{1.25 \times 1.60 \times 10^{-19}}{45}$
- C  $\frac{1.60 \times 10^{-19}}{1.25 \times 45}$
- D  $\frac{45}{1.25 \times 1.60 \times 10^{-19}}$

(Total for Question 7 = 1 mark)

8 A ray of light is incident on a glass block, as shown.

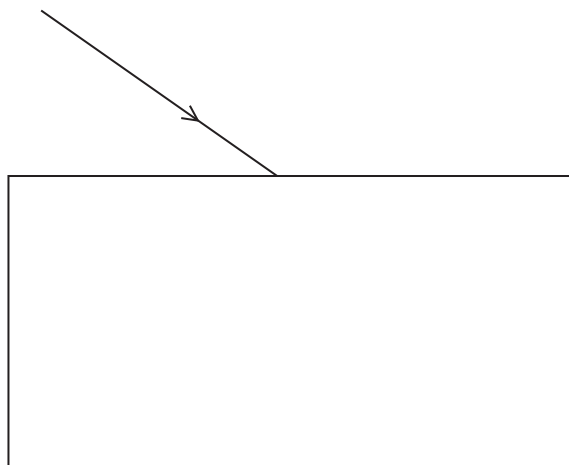

Which of the following does **not** occur when the ray of light is incident on the glass block?

- A diffraction
- B polarisation
- C reflection
- D refraction

(Total for Question 8 = 1 mark)

DO NOT WRITE IN THIS AREA

DO NOT WRITE IN THIS AREA

DO NOT WRITE IN THIS AREA



P 7 1 8 7 9 A 0 5 2 4

9 Ultrasound scans can be used to create an image of a patient's kidneys.

For each ultrasound pulse sent into the body, a number of pulses are detected.

Which of the following explains why a number of pulses are detected?

- A Interference occurs when the pulse is in the body.
- B The ultrasound reflects off different layers within the body.
- C The ultrasound has a very high frequency.
- D The ultrasound has a very large wavelength.

(Total for Question 9 = 1 mark)

10 Which of the following units is equivalent to the volt?

- A  $Cs^{-1}$
- B  $J s^{-1}$
- C  $J C^{-1}$
- D  $J s$

(Total for Question 10 = 1 mark)

**TOTAL FOR SECTION A = 10 MARKS**

DO NOT WRITE IN THIS AREA

DO NOT WRITE IN THIS AREA

DO NOT WRITE IN THIS AREA





DO NOT WRITE IN THIS AREA

DO NOT WRITE IN THIS AREA

DO NOT WRITE IN THIS AREA

**BLANK PAGE**



12 A student carries out an experiment to determine the e.m.f.  $\varepsilon$  and internal resistance  $r$  of an electrical cell, using a circuit containing an ammeter and a voltmeter.

(a) Draw a diagram of a circuit that can be used for this experiment.

(3)

(b) The student plotted a graph of the terminal potential difference  $V$  of the cell against the current  $I$  in the cell, as shown.

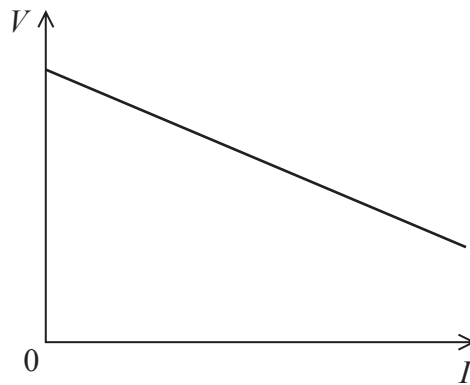

Explain how  $\varepsilon$  and  $r$  for the cell can be determined from this graph.

(4)

(Total for Question 12 = 7 marks)



- 13 A student sets up the circuit shown with a cell of negligible internal resistance.  
The ammeter displays a current of 0.14 A.

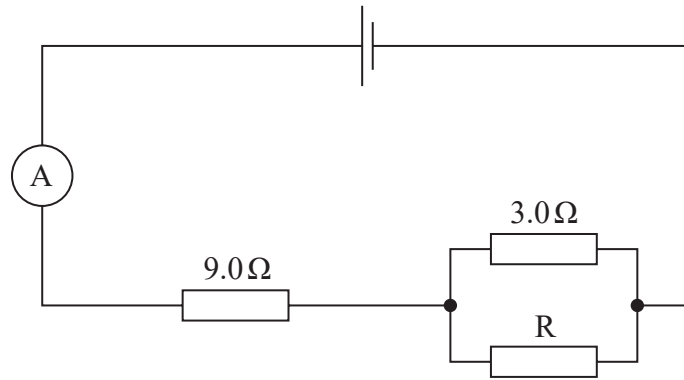

- (a) Calculate a value for the resistance of the resistor R.

e.m.f. of the cell = 1.54 V

(4)

Resistance = .....

DO NOT WRITE IN THIS AREA

DO NOT WRITE IN THIS AREA

DO NOT WRITE IN THIS AREA



(b) The student made the  $9.0\ \Omega$  resistor using a thin copper wire with a diameter of  $0.15\ \text{mm}$ .

(i) Show that the cross-sectional area of this wire was about  $2 \times 10^{-8}\ \text{m}^2$ .

(2)

(ii) Calculate the length of copper wire used by the student.

resistivity of copper =  $1.68 \times 10^{-8}\ \Omega\text{m}$

(2)

Length of copper wire = .....

(iii) Calculate the drift velocity of the electrons in this copper wire.

number of charge carriers per unit volume =  $8.49 \times 10^{28}\ \text{m}^{-3}$

current in copper wire =  $0.14\ \text{A}$

(2)

Drift velocity = .....

**(Total for Question 13 = 10 marks)**

DO NOT WRITE IN THIS AREA

DO NOT WRITE IN THIS AREA

DO NOT WRITE IN THIS AREA



P 7 1 8 7 9 A 0 1 1 2 4

14 Monochromatic light is incident on the surface of a magnesium plate. Electrons are released with a range of kinetic energies.

- (a) Explain why the maximum kinetic energy of a released electron is less than the energy of each photon of light incident on the surface.

(3)

DO NOT WRITE IN THIS AREA

DO NOT WRITE IN THIS AREA

DO NOT WRITE IN THIS AREA



- (b) The frequencies of three different sources of light, A, B and C, are shown in the table below.

Light source	Frequency / $10^{15}$ Hz
A	1.11
B	1.23
C	1.34

The light from one of these sources was incident on the magnesium plate, and electrons were released with a maximum speed of  $5.70 \times 10^5 \text{ m s}^{-1}$ .

Deduce which of the three sources of light was used.

work function of magnesium = 3.68 eV

(4)

(Total for Question 14 = 7 marks)

DO NOT WRITE IN THIS AREA

DO NOT WRITE IN THIS AREA

DO NOT WRITE IN THIS AREA



15 The human ear can only hear two sounds as separate frequencies when the difference in frequency between the sounds is greater than 0.3%.

Sounds with a difference in frequency less than 0.3% are heard as the same frequency.

(a) Two sounds with frequencies of 880 Hz and 882 Hz are produced.

(i) Show that the person hears these two sounds as the same frequency.

(2)

\*(ii) When listening to these two sounds at the same time, the loudness of the sound increases and decreases repeatedly.

Explain why. Your answer should refer to coherence and phase difference.

(6)

DO NOT WRITE IN THIS AREA

DO NOT WRITE IN THIS AREA

DO NOT WRITE IN THIS AREA



- (b) A wire is stretched between two fixed points. The wire is made to vibrate and a stationary wave is created. This produces a sound wave in the air.

The fixed ends of the wire act as nodes (N). There is an antinode (A) in the middle of the wire, as shown.

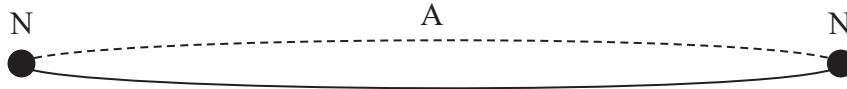

A wire of length 18.7 cm produces a sound with a frequency of 882 Hz.  
The tension in the wire is adjusted until the frequency of the sound is 880 Hz.

Calculate the decrease in tension required to cause this change in frequency.

mass per unit length of wire =  $5.08 \times 10^{-3} \text{ kg m}^{-1}$

(4)

Decrease in tension = .....

**(Total for Question 15 = 12 marks)**

DO NOT WRITE IN THIS AREA

DO NOT WRITE IN THIS AREA

DO NOT WRITE IN THIS AREA



P 7 1 8 7 9 A 0 1 5 2 4

- 16 An optical fibre consists of a core material surrounded by a material of lower refractive index called cladding.

A ray of light approaches the boundary between the core and the cladding, as shown.

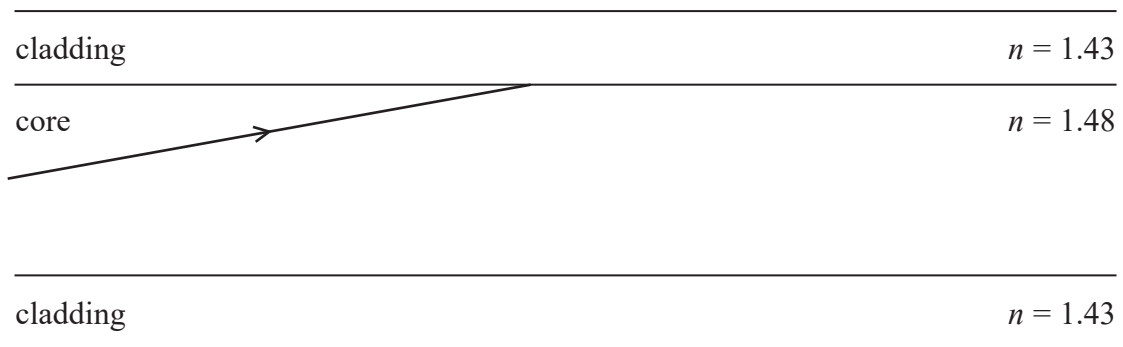

- (a) (i) Show that the critical angle for light incident on the boundary between the core and cladding is about  $75^\circ$ .

(3)

- (ii) Explain what will happen to the ray of light after it meets the boundary between the core and cladding.

The diagram is drawn to scale and you should use a measurement taken from the diagram.

(3)



(b) The path of another ray of light through the core of the optical fibre is shown.

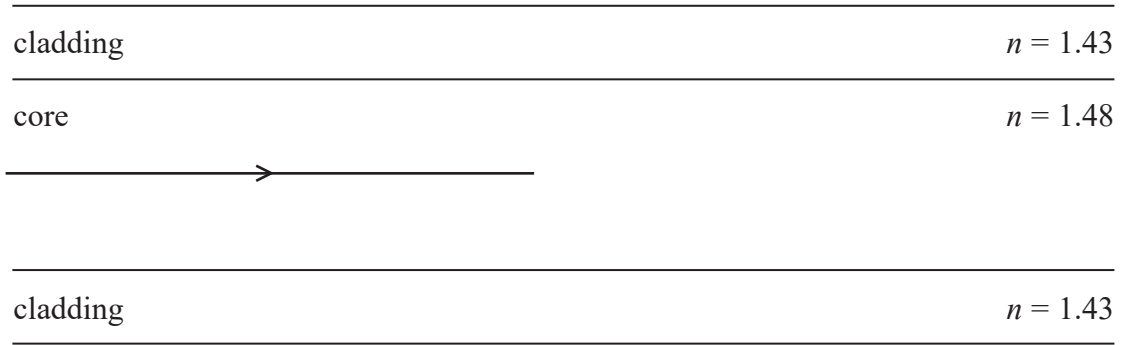

(i) Calculate the time taken for light to travel in a straight line along 70.0 km of this optical fibre.

(3)

Time taken = .....

(ii) Light may escape from the core into the cladding when the optical fibre is curved.

A student suggests that using cladding with a lower refractive index would lead to less light escaping from the core.

Explain why the student's suggestion is correct.

(2)

(Total for Question 16 = 11 marks)

DO NOT WRITE IN THIS AREA

DO NOT WRITE IN THIS AREA

DO NOT WRITE IN THIS AREA



17 A red light-emitting diode (LED) was placed into a circuit, as shown.

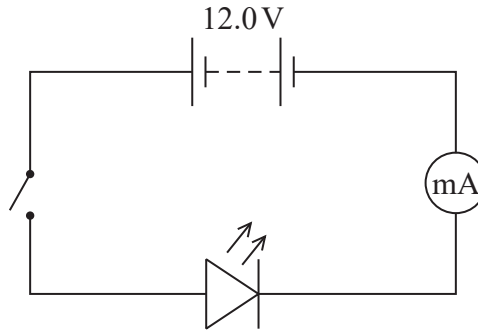

The LED emits light of wavelength of 627 nm and may be assumed to be 100% efficient. The battery has negligible internal resistance.

When the switch was closed, the reading on the ammeter was 9.2 mA.

(a) (i) Show that the power of the LED was about 0.1 W.

(2)

(ii) Calculate the number of photons emitted by the LED in one minute.

(4)

Number of photons emitted in one minute = .....

DO NOT WRITE IN THIS AREA

DO NOT WRITE IN THIS AREA

DO NOT WRITE IN THIS AREA





- 18 A student directed light from a laser so that the light was incident on a diffraction grating at  $90^\circ$ . The student placed a screen a distance  $x$  from the grating and observed a series of bright maxima of order  $n$  on the screen.

The student determined the value of  $\theta_1$  shown on the diagram.

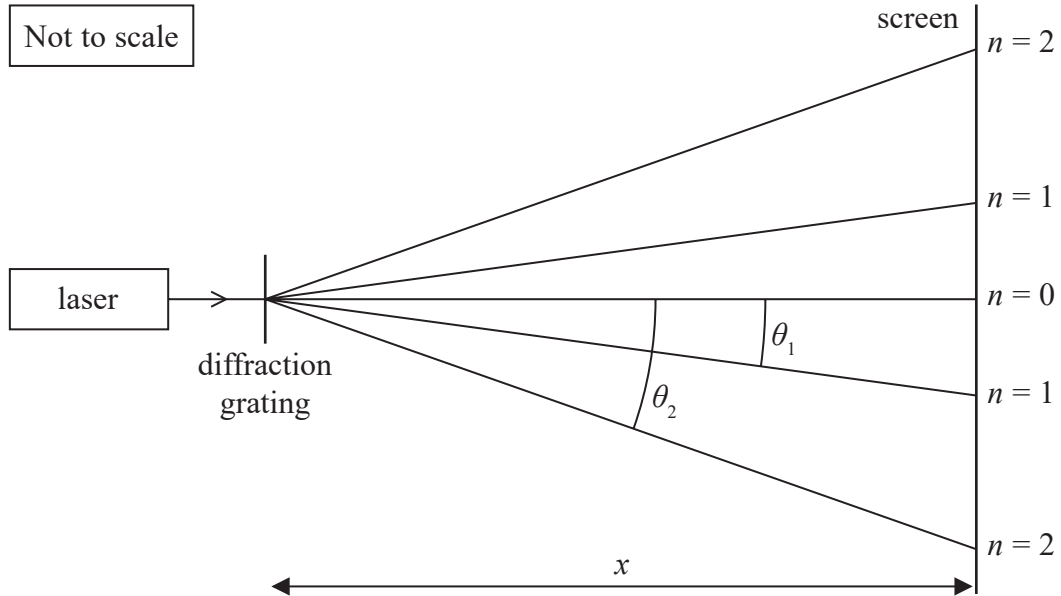

The angle  $\theta_1$  is  $14.0^\circ$ .

- (a) Calculate the angle  $\theta_2$ .

(2)

$\theta_2 = \dots\dots\dots$



DO NOT WRITE IN THIS AREA

DO NOT WRITE IN THIS AREA

DO NOT WRITE IN THIS AREA

(b) The student measured  $\theta$  for values of  $n$  from 1 to 4.

Describe how a graphical method can be used to determine the wavelength of the light from the laser. Assume that the value of the grating spacing  $d$  is known.

(3)

.....

.....

.....

.....

.....

.....

(c) In a separate experiment, the student uses a different diffraction grating that has been labelled as “300 lines per mm” by another student. The distance measured on the screen between the  $n = 0$  maximum and the  $n = 2$  maximum is 0.397 m.

Deduce whether the labelling of the diffraction grating is correct.

distance  $x$  from diffraction grating to screen = 2.00 m  
wavelength of laser light = 650 nm

(4)

.....

.....

.....

.....

.....

.....

.....

.....

.....

.....

.....

(Total for Question 18 = 9 marks)

**TOTAL FOR SECTION B = 70 MARKS**  
**TOTAL FOR PAPER = 80 MARKS**



**List of data, formulae and relationships**

Acceleration of free fall	$g = 9.81 \text{ m s}^{-2}$	(close to Earth's surface)
Electron charge	$e = -1.60 \times 10^{-19} \text{ C}$	
Electron mass	$m_e = 9.11 \times 10^{-31} \text{ kg}$	
Electronvolt	$1 \text{ eV} = 1.60 \times 10^{-19} \text{ J}$	
Gravitational field strength	$g = 9.81 \text{ N kg}^{-1}$	(close to Earth's surface)
Planck constant	$h = 6.63 \times 10^{-34} \text{ J s}$	
Speed of light in a vacuum	$c = 3.00 \times 10^8 \text{ m s}^{-1}$	

**Unit 1***Mechanics*

Kinematic equations of motion

$$s = \frac{(u + v)t}{2}$$

$$v = u + at$$

$$s = ut + \frac{1}{2}at^2$$

$$v^2 = u^2 + 2as$$

Forces

$$\Sigma F = ma$$

$$g = \frac{F}{m}$$

$$W = mg$$

Momentum

$$p = mv$$

Moment of force

$$\text{moment} = Fx$$

Work and energy

$$\Delta W = F\Delta s$$

$$E_k = \frac{1}{2}mv^2$$

Power

$$\Delta E_{\text{grav}} = mg\Delta h$$

$$P = \frac{E}{t}$$

$$P = \frac{W}{t}$$

DO NOT WRITE IN THIS AREA

DO NOT WRITE IN THIS AREA

DO NOT WRITE IN THIS AREA



Efficiency

$$\text{efficiency} = \frac{\text{useful energy output}}{\text{total energy input}}$$

$$\text{efficiency} = \frac{\text{useful power output}}{\text{total power input}}$$

*Materials*

Density

$$\rho = \frac{m}{V}$$

Stokes' law

$$F = 6\pi\eta rv$$

Hooke's law

$$\Delta F = k\Delta x$$

Elastic strain energy

$$\Delta E_{\text{el}} = \frac{1}{2}F\Delta x$$

Young modulus

$$E = \frac{\sigma}{\varepsilon} \text{ where}$$

$$\text{Stress } \sigma = \frac{F}{A}$$

$$\text{Strain } \varepsilon = \frac{\Delta x}{x}$$

DO NOT WRITE IN THIS AREA

DO NOT WRITE IN THIS AREA

DO NOT WRITE IN THIS AREA



P 7 1 8 7 9 A 0 2 3 2 4

**Unit 2***Waves*

Wave speed

$$v = f\lambda$$

Speed of a transverse wave on a string

$$v = \sqrt{\frac{T}{\mu}}$$

Intensity of radiation

$$I = \frac{P}{A}$$

Refractive index

$$n_1 \sin \theta_1 = n_2 \sin \theta_2$$

$$n = \frac{c}{v}$$

Critical angle

$$\sin C = \frac{1}{n}$$

Diffraction grating

$$n\lambda = d \sin \theta$$

*Electricity*

Potential difference

$$V = \frac{W}{Q}$$

Resistance

$$R = \frac{V}{I}$$

Electrical power, energy

$$P = VI$$

$$P = I^2R$$

$$P = \frac{V^2}{R}$$

$$W = VI t$$

Resistivity

$$R = \frac{\rho l}{A}$$

Current

$$I = \frac{\Delta Q}{\Delta t}$$

$$I = nqvA$$

Resistors in series

$$R = R_1 + R_2 + R_3$$

Resistors in parallel

$$\frac{1}{R} = \frac{1}{R_1} + \frac{1}{R_2} + \frac{1}{R_3}$$

*Particle nature of light*

Photon model

$$E = hf$$

Einstein's photoelectric equation

$$hf = \phi + \frac{1}{2}mv_{\max}^2$$

de Broglie wavelength

$$\lambda = \frac{h}{p}$$

DO NOT WRITE IN THIS AREA

DO NOT WRITE IN THIS AREA

DO NOT WRITE IN THIS AREA

