

Please check the examination details below before entering your candidate information

Candidates surname					Other names				
Centre Number					Candidate Number				
<input type="text"/>	<input type="text"/>	<input type="text"/>	<input type="text"/>	<input type="text"/>	<input type="text"/>	<input type="text"/>	<input type="text"/>	<input type="text"/>	<input type="text"/>

Pearson Edexcel International Advanced Level

Time 1 hour 45 minutes

Paper reference **WPH14/01**

Physics

International Advanced Level

UNIT 4: Further Mechanics, Fields and Particles

You must have:
Scientific calculator, ruler

Total Marks

Instructions

- Use **black** ink or ball-point pen.
- If pencil is used for diagrams/sketches/graphs it must be dark (HB or B).
- **Fill in the boxes** at the top of this page with your name, centre number and candidate number.
- Answer **all** questions.
- Answer the questions in the spaces provided
– *there may be more space than you need.*
- **Show all your working out** in calculations and **include units** where appropriate.

Information

- The total mark for this paper is 90.
- The marks for **each** question are shown in brackets
– *use this as a guide as to how much time to spend on each question.*
- In the question marked with an **asterisk (*)**, marks will be awarded for your ability to structure your answer logically, showing how the points that you make are related or follow on from each other where appropriate.
- The list of data, formulae and relationships is printed at the end of this booklet.

Advice

- Read each question carefully before you start to answer it.
- Try to answer every question.
- Check your answers if you have time at the end.

Turn over ►

P71890RA

©2023 Pearson Education Ltd.

J:1/1/1/1/1/



Pearson

SECTION A

Answer ALL questions.

For questions 1–10, in Section A, select one answer from A to D and put a cross in the box . If you change your mind, put a line through the box and then mark your new answer with a cross .

- 1 The table shows the charges on up quarks and down quarks.

Quark	Charge / e
u	$+\frac{2}{3}$
d	$-\frac{1}{3}$

Which row of the table shows the quark structure of protons and neutrons?

	Proton	Neutron
<input type="checkbox"/> A	ddd	uuu
<input type="checkbox"/> B	ddu	uud
<input type="checkbox"/> C	duu	ddu
<input type="checkbox"/> D	uuu	ddd

(Total for Question 1 = 1 mark)

- 2 A laboratory centrifuge rotates at 1500 revolutions per minute.

Which of the following expressions gives the angular velocity in radians per second?

- A $\frac{1500}{60 \times 2\pi}$
- B $\frac{60}{1500 \times 2\pi}$
- C $\frac{60 \times 2\pi}{1500}$
- D $\frac{1500 \times 2\pi}{60}$

(Total for Question 2 = 1 mark)



- 3 A nucleus of element X emits an alpha particle to produce the nucleus ${}_{91}^{233}\text{Y}$.

Which of the following is the correct nucleon structure of element X?

- A 95 protons and 235 neutrons
- B 93 protons and 144 neutrons
- C 93 protons and 237 neutrons
- D 89 protons and 138 neutrons

(Total for Question 3 = 1 mark)

- 4 The diagram shows the track of a charged particle in a magnetic field.

The magnetic field is directed into the page.

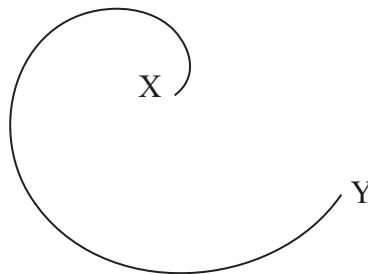

Which of the following particles could create this track?

- A a muon travelling from X to Y
- B a positron travelling from Y to X
- C a π^+ travelling from X to Y
- D an electron travelling from Y to X

(Total for Question 4 = 1 mark)

- 5 Which of the following statements is **not** a valid conclusion from alpha particle scattering experiments?

- A Most of the atom is empty space.
- B Most of the mass of the atom is concentrated in the nucleus.
- C The nucleus contains all of the charge of the atom.
- D The radius of the nucleus is very small compared to the radius of the atom.

(Total for Question 5 = 1 mark)



6 Point charges of equal magnitude are placed close together, as shown.

⊖

⊕

Which of the following diagrams shows the electric field around the charges?

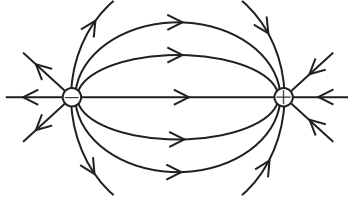

A

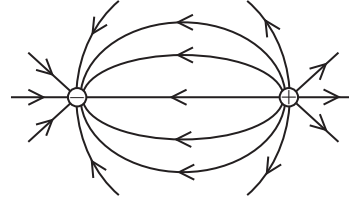

B

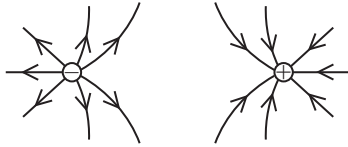

C

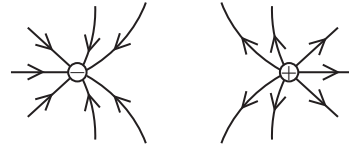

D

- A
- B
- C
- D

(Total for Question 6 = 1 mark)

7 Which of the following statements is true for a cyclotron?

- A A cyclotron can be used to accelerate neutrons.
- B A cyclotron uses a magnetic field to increase the speed of particles.
- C A cyclotron uses an alternating potential difference at a constant frequency.
- D A cyclotron uses an electric field to keep particles moving in a circular path.

(Total for Question 7 = 1 mark)



8 A non-relativistic particle of mass m has momentum p and kinetic energy E_k .

A second non-relativistic particle of mass $\frac{m}{2}$ has momentum $2p$.

Which of the following expressions gives the kinetic energy of the second particle?

- A $\frac{E_k}{2}$
- B E_k
- C $2E_k$
- D $8E_k$

(Total for Question 8 = 1 mark)

9 A ball travelling at speed u towards a wall collides with the wall at right angles. The ball bounces off the wall at speed v in the opposite direction. The time for the collision is t .

Which of the following expressions gives the average force on the wall during the collision?

- A $\frac{m(u + v)}{t}$
- B $\frac{m(u + v)}{2t}$
- C $\frac{m(u - v)}{t}$
- D $\frac{m(u - v)}{2t}$

(Total for Question 9 = 1 mark)

10 A proton is accelerated by a uniform electric field. After time t the speed of the proton has increased by Δv .

A helium nucleus ${}^4_2\text{He}$ is accelerated by the same electric field.

After what time will the helium nucleus achieve the same change in speed?

- A $4t$
- B $2t$
- C $\frac{t}{2}$
- D $\frac{t}{4}$

(Total for Question 10 = 1 mark)

TOTAL FOR SECTION A = 10 MARKS



SECTION B

Answer ALL questions. Write your answers in the spaces provided.

- 11 A muon will decay into a neutrino, an antineutrino and an electron or a positron. A positron is the antiparticle of an electron.

(a) State one difference between a positron and an electron.

(1)

(b) Explain whether the following decay would be possible.

You should consider conservation of charge and lepton number.

$$\mu^- \rightarrow e^- + \nu_e + \bar{\nu}_\mu$$

(3)

(Total for Question 11 = 4 marks)

DO NOT WRITE IN THIS AREA

DO NOT WRITE IN THIS AREA

DO NOT WRITE IN THIS AREA



DO NOT WRITE IN THIS AREA

DO NOT WRITE IN THIS AREA

DO NOT WRITE IN THIS AREA

BLANK PAGE



P 7 1 8 9 0 R A 0 7 3 2

12 A point charge is placed at point X, as shown.

•
X

(a) Add lines to the diagram to show equipotentials at intervals of equal potential difference.

(2)

(b) A charge of -4.5 nC is placed 4.0 cm from X.

Calculate the magnitude of the force acting on this charge due to the charge at X.
charge at X = $+7.0 \text{ nC}$

(2)

Magnitude of force =

DO NOT WRITE IN THIS AREA

DO NOT WRITE IN THIS AREA

DO NOT WRITE IN THIS AREA



- (c) The -4.5 nC charge is moved from a distance of 4.0 cm from X to a distance of 9.0 cm from X.

Calculate the work done on the -4.5 nC charge.

(3)

Work done =

(Total for Question 12 = 7 marks)

DO NOT WRITE IN THIS AREA

DO NOT WRITE IN THIS AREA

DO NOT WRITE IN THIS AREA



P 7 1 8 9 0 R A 0 9 3 2

DO NOT WRITE IN THIS AREA

DO NOT WRITE IN THIS AREA

DO NOT WRITE IN THIS AREA

BLANK PAGE



13 There are four forces acting on an aeroplane in flight, as shown.

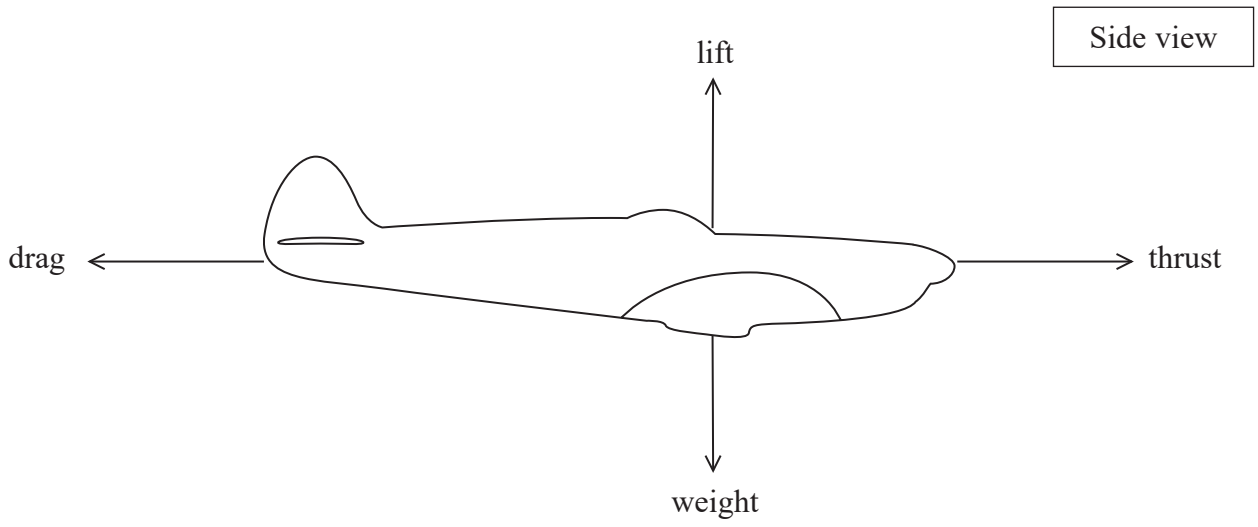

DO NOT WRITE IN THIS AREA

DO NOT WRITE IN THIS AREA

DO NOT WRITE IN THIS AREA



P 7 1 8 9 0 R A 0 1 1 3 2

- (a) The lift force is perpendicular to the wings.

To change direction, the aeroplane 'banks' so that one wing is lower than the other wing.

The lift force is then no longer vertical.

The aeroplane flies in a horizontal circular path at a speed of 52 m s^{-1} .

The diagram below shows the aeroplane banking at an angle of 20° to the horizontal.

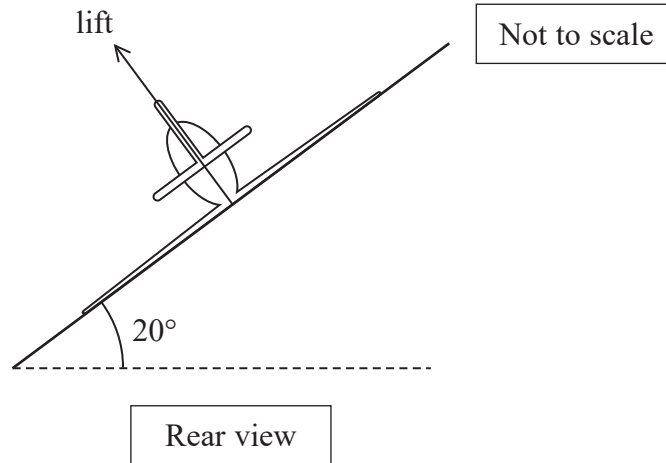

- (i) Show that the radius of the circular path is about 800 m.

mass of aeroplane = 1200 kg
speed of aeroplane = 54 m s^{-1}

(5)

.....

.....

.....

.....

.....

.....

.....

.....

.....

.....

DO NOT WRITE IN THIS AREA

DO NOT WRITE IN THIS AREA

DO NOT WRITE IN THIS AREA



- (ii) Determine the time taken by the plane to move through 90° of the circular path.

$$\text{speed of aeroplane} = 54 \text{ m s}^{-1}$$

(2)

Time =

- (b) The wings of the aeroplane are now levelled, as shown below.
The speed and the magnitude of the lift force remain the same.

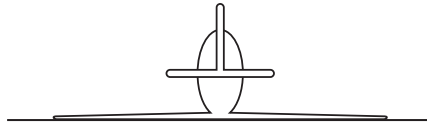

Explain what will happen to the vertical motion of the aeroplane.

(2)

(Total for Question 13 = 9 marks)



P 7 1 8 9 0 R A 0 1 3 3 2

14 A student used a spreadsheet to model the conservation of momentum.

(a) State the principle of conservation of momentum.

(2)

.....

.....

.....

.....

(b) The spreadsheet modelled an elastic collision between object A and object B.

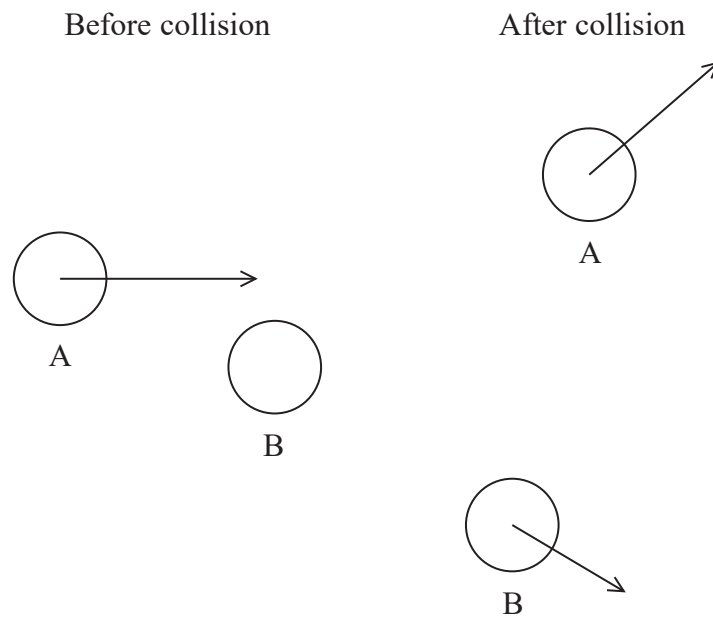

The spreadsheet shows the initial values and final values when the student tested the model.

	A	B	C	D	E
1		Initial values		Final values	
2		object A	object B	object A	object B
3	mass / kg	0.85	1.70	0.85	1.70
4	magnitude of velocity / m s^{-1}	1.30	0.00	0.98	0.54
5	angle of velocity to x direction / $^{\circ}$	0.0	0.0	54.5	-48.0
6					

DO NOT WRITE IN THIS AREA

DO NOT WRITE IN THIS AREA

DO NOT WRITE IN THIS AREA



(i) Deduce whether the values show an elastic collision.

(3)

(ii) Deduce whether the values show the conservation of momentum.

(5)

(Total for Question 14 = 10 marks)

DO NOT WRITE IN THIS AREA

DO NOT WRITE IN THIS AREA

DO NOT WRITE IN THIS AREA



P 7 1 8 9 0 R A 0 1 5 3 2

DO NOT WRITE IN THIS AREA

DO NOT WRITE IN THIS AREA

DO NOT WRITE IN THIS AREA

BLANK PAGE



16 A student was investigating capacitors and set up the circuit shown.

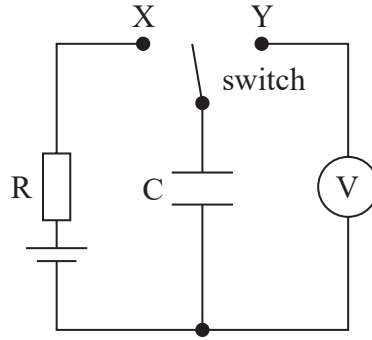

The student planned to use the circuit to measure the potential difference V across the capacitor C as it was charged and discharged through the resistor R .

(a) Give two reasons why the circuit did not operate as intended.

(2)

.....

.....

.....

.....



(b) The student moved the switch from position X to position Y at time $t = 0$ s.

The student recorded values of V as t increased and plotted the graph shown.

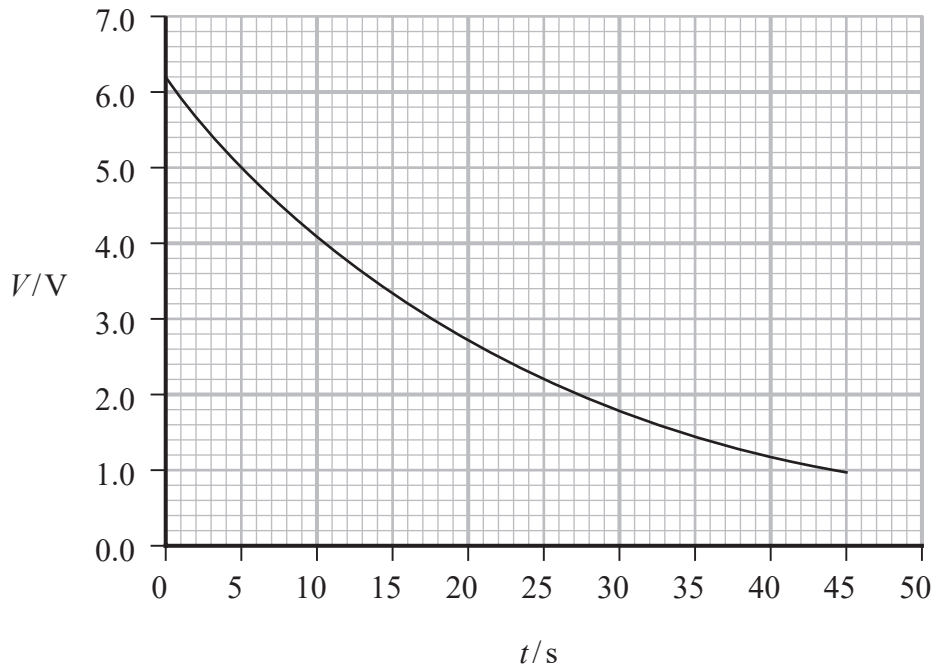

The capacitance of capacitor C was $2.2 \mu\text{F}$.

(i) Determine the resistance in the circuit when the switch was at position Y.

(3)

Resistance =

DO NOT WRITE IN THIS AREA

DO NOT WRITE IN THIS AREA

DO NOT WRITE IN THIS AREA



(ii) Determine the average current in the circuit between $t = 0$ s and $t = 30$ s.

(4)

Average current =

(iii) Calculate the energy dissipated by the current in the circuit between $t = 0$ s and $t = 30$ s.

(3)

Energy dissipated =

(Total for Question 16 = 12 marks)

DO NOT WRITE IN THIS AREA

DO NOT WRITE IN THIS AREA

DO NOT WRITE IN THIS AREA



P 7 1 8 9 0 R A 0 2 1 3 2

17 (a) In 1897 J J Thomson demonstrated that electrons are small negative particles.

The diagram shows the apparatus used by Thomson.

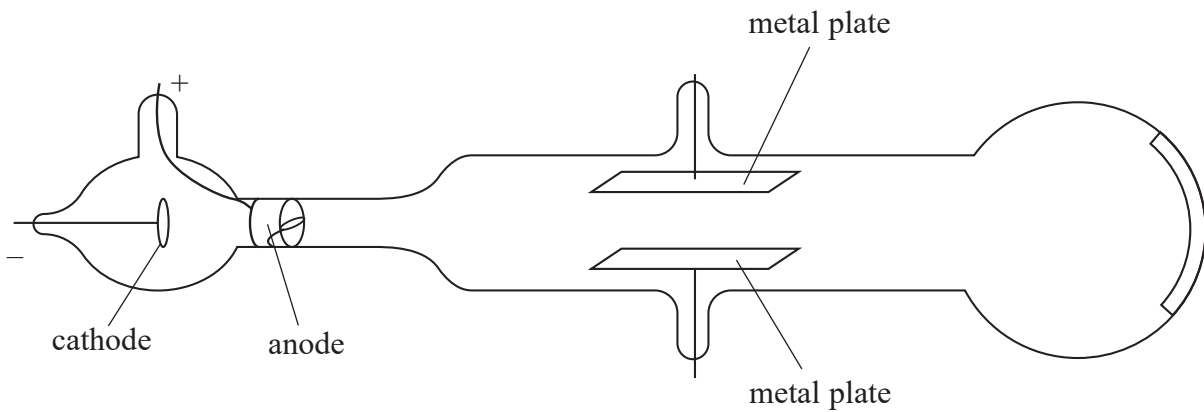

(Source: J.J. Thomson © Philosophical Magazine, 44, 293 (1897))

A potential difference V was applied across the metal plates, producing an electric field between them.

A magnetic field of flux density B was applied at right angles to the electric field.

Electrons were emitted from the cathode and accelerated towards the anode. The electrons moved between the metal plates with a speed v .

Thomson adjusted B until the electric and magnetic forces on the electrons were equal and opposite, so the electrons passed between the metal plates in a straight line.

(i) The plates are separated by a distance d .

Show that the speed v of the electrons is given by

$$v = \frac{V}{Bd}$$

(3)

.....

.....

.....

.....

.....

.....

.....

DO NOT WRITE IN THIS AREA

DO NOT WRITE IN THIS AREA

DO NOT WRITE IN THIS AREA



- (ii) An experiment was carried out using similar apparatus.

Show that v was about $3 \times 10^7 \text{ m s}^{-1}$.

$$d = 1.5 \text{ cm}$$

$$B = 5.5 \times 10^{-4} \text{ T}$$

$$V = 231 \text{ V}$$

(2)

- (iii) When the electric field between the plates is switched off the electrons move in a circular path of radius 39 cm, due to the magnetic field.

The accepted value for the charge per unit mass of an electron is $1.8 \times 10^{11} \text{ C kg}^{-1}$.

Deduce whether the charge per unit mass of an electron calculated using data from this experiment is consistent with the accepted value.

$$B = 5.5 \times 10^{-4} \text{ T}$$

(3)

DO NOT WRITE IN THIS AREA

DO NOT WRITE IN THIS AREA

DO NOT WRITE IN THIS AREA



P 7 1 8 9 0 R A 0 2 3 3 2

(b) In 1927 J J Thomson's son directed beams of electrons at thin films of metal.

The photograph shows one of the patterns observed.

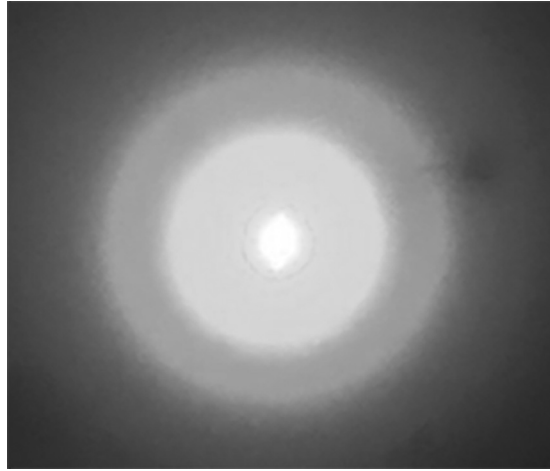

Explain how this pattern changed scientists' understanding about the nature of electrons.

(3)

.....

.....

.....

.....

.....

.....

(Total for Question 17 = 11 marks)

DO NOT WRITE IN THIS AREA

DO NOT WRITE IN THIS AREA

DO NOT WRITE IN THIS AREA



18 In 1977 a fifth quark, named the bottom quark, was discovered by particle physicists.

The table shows the particles in the standard model known at that time.

Quarks		Leptons	
up	down	electron	electron neutrino
strange	charm	muon	muon neutrino
bottom		tau	

(a) (i) Explain why the existence of a sixth quark was predicted.

(3)

(ii) A short time after formation, most quarks combine to make particles known as hadrons. There are two categories of hadron.

Name the two categories of hadron.

(1)

DO NOT WRITE IN THIS AREA

DO NOT WRITE IN THIS AREA

DO NOT WRITE IN THIS AREA



P 7 1 8 9 0 R A 0 2 5 3 2

- (b) In 1995 the sixth quark, known as the top quark, was discovered using the Tevatron collider at Fermilab. A collision of a proton with an anti-proton produced a top quark and a top anti-quark.

Particle experiments may direct beams of particles at stationary targets or collide beams of particles travelling in opposite directions.

- (i) Explain the advantage of colliding beams of particles.

(4)

- (ii) In the collider experiment, the protons and anti-protons each had total energy 900 GeV.

Calculate the maximum kinetic energy, in joules, of a top quark produced in this experiment.

rest energy of top quark = 173 GeV

(3)

Maximum kinetic energy = J

DO NOT WRITE IN THIS AREA

DO NOT WRITE IN THIS AREA

DO NOT WRITE IN THIS AREA



- (iii) Deduce whether a top quark with kinetic energy $1.2 \times 10^{-7} \text{ J}$ is travelling at a relativistic speed.

rest mass of top quark = $173 \text{ GeV}/c^2$

(3)

DO NOT WRITE IN THIS AREA

DO NOT WRITE IN THIS AREA

DO NOT WRITE IN THIS AREA

- (c) Most types of quark form hadrons on a timescale of 10^{-23} s . The top quark does not form hadrons because its lifetime is only 10^{-25} s .

A student suggests that, if the top quarks travelled at relativistic speeds, it could be possible for them to form hadrons.

Assess this suggestion.

(2)

(Total for Question 18 = 16 marks)

TOTAL FOR SECTION B = 80 MARKS

TOTAL FOR PAPER = 90 MARKS



List of data, formulae and relationships

Acceleration of free fall	$g = 9.81 \text{ m s}^{-2}$	(close to Earth's surface)
Boltzmann constant	$k = 1.38 \times 10^{-23} \text{ J K}^{-1}$	
Coulomb's law constant	$k = 1/4\pi\epsilon_0$ $= 8.99 \times 10^9 \text{ N m}^2 \text{ C}^{-2}$	
Electron charge	$e = -1.60 \times 10^{-19} \text{ C}$	
Electron mass	$m_e = 9.11 \times 10^{-31} \text{ kg}$	
Electronvolt	$1 \text{ eV} = 1.60 \times 10^{-19} \text{ J}$	
Gravitational constant	$G = 6.67 \times 10^{-11} \text{ N m}^2 \text{ kg}^{-2}$	
Gravitational field strength	$g = 9.81 \text{ N kg}^{-1}$	(close to Earth's surface)
Permittivity of free space	$\epsilon_0 = 8.85 \times 10^{-12} \text{ F m}^{-1}$	
Planck constant	$h = 6.63 \times 10^{-34} \text{ J s}$	
Proton mass	$m_p = 1.67 \times 10^{-27} \text{ kg}$	
Speed of light in a vacuum	$c = 3.00 \times 10^8 \text{ m s}^{-1}$	
Stefan-Boltzmann constant	$\sigma = 5.67 \times 10^{-8} \text{ W m}^{-2} \text{ K}^{-4}$	
Unified atomic mass unit	$u = 1.66 \times 10^{-27} \text{ kg}$	

Unit 1*Mechanics*

Kinematic equations of motion

$$s = \frac{(u + v)t}{2}$$

$$v = u + at$$

$$s = ut + \frac{1}{2}at^2$$

$$v^2 = u^2 + 2as$$

Forces

$$\Sigma F = ma$$

$$g = \frac{F}{m}$$

$$W = mg$$

Momentum

$$p = mv$$

Moment of force

$$\text{moment} = Fx$$

Work and energy

$$\Delta W = F\Delta s$$

$$E_k = \frac{1}{2}mv^2$$

$$\Delta E_{\text{grav}} = mg\Delta h$$

Power

$$P = \frac{E}{t}$$

$$P = \frac{W}{t}$$

DO NOT WRITE IN THIS AREA

DO NOT WRITE IN THIS AREA

DO NOT WRITE IN THIS AREA



Efficiency

$$\text{efficiency} = \frac{\text{useful energy output}}{\text{total energy input}}$$

$$\text{efficiency} = \frac{\text{useful power output}}{\text{total power input}}$$

Materials

Density

$$\rho = \frac{m}{V}$$

Stokes' law

$$F = 6\pi\eta rv$$

Hooke's law

$$\Delta F = k\Delta x$$

Elastic strain energy

$$\Delta E_{\text{el}} = \frac{1}{2}F\Delta x$$

Young modulus

$$E = \frac{\sigma}{\varepsilon} \text{ where}$$

$$\text{Stress } \sigma = \frac{F}{A}$$

$$\text{Strain } \varepsilon = \frac{\Delta x}{x}$$

DO NOT WRITE IN THIS AREA

DO NOT WRITE IN THIS AREA

DO NOT WRITE IN THIS AREA



P 7 1 8 9 0 R A 0 2 9 3 2

Unit 2*Waves*

Wave speed $v = f\lambda$

Speed of a transverse wave on a string $v = \sqrt{\frac{T}{\mu}}$

Intensity of radiation $I = \frac{P}{A}$

Refractive index $n_1 \sin \theta_1 = n_2 \sin \theta_2$
 $n = \frac{c}{v}$

Critical angle $\sin C = \frac{1}{n}$

Diffraction grating $n\lambda = d \sin \theta$

Electricity

Potential difference $V = \frac{W}{Q}$

Resistance $R = \frac{V}{I}$

Electrical power, energy $P = VI$
 $P = I^2R$
 $P = \frac{V^2}{R}$
 $W = VI t$

Resistivity $R = \frac{\rho l}{A}$

Current $I = \frac{\Delta Q}{\Delta t}$
 $I = nqvA$

Resistors in series $R = R_1 + R_2 + R_3$

Resistors in parallel $\frac{1}{R} = \frac{1}{R_1} + \frac{1}{R_2} + \frac{1}{R_3}$

Particle nature of light

Photon model $E = hf$

Einstein's photoelectric equation $hf = \phi + \frac{1}{2}mv_{\max}^2$

de Broglie wavelength $\lambda = \frac{h}{p}$

DO NOT WRITE IN THIS AREA

DO NOT WRITE IN THIS AREA

DO NOT WRITE IN THIS AREA



Unit 4*Further mechanics*

Impulse

$$F\Delta t = \Delta p$$

Kinetic energy of a non-relativistic particle

$$E_k = \frac{p^2}{2m}$$

Motion in a circle

$$v = \omega r$$

$$T = \frac{2\pi}{\omega}$$

$$a = \frac{v^2}{r}$$

$$a = r\omega^2$$

Centripetal force

$$F = ma = \frac{mv^2}{r}$$

$$F = mr\omega^2$$

Electric and magnetic fields

Electric field

$$E = \frac{F}{Q}$$

Coulomb's law

$$F = \frac{Q_1 Q_2}{4\pi\epsilon_0 r^2}$$

$$E = \frac{Q}{4\pi\epsilon_0 r^2}$$

$$E = \frac{V}{d}$$

Electrical potential

$$V = \frac{Q}{4\pi\epsilon_0 r}$$

Capacitance

$$C = \frac{Q}{V}$$

Energy stored in capacitor

$$W = \frac{1}{2} QV$$

$$W = \frac{1}{2} CV^2$$

$$W = \frac{1}{2} \frac{Q^2}{C}$$

Capacitor discharge

$$Q = Q_0 e^{-t/RC}$$

DO NOT WRITE IN THIS AREA

DO NOT WRITE IN THIS AREA

DO NOT WRITE IN THIS AREA



Resistor-capacitor discharge

$$I = I_0 e^{-t/RC}$$

$$V = V_0 e^{-t/RC}$$

$$\ln Q = \ln Q_0 - \frac{t}{RC}$$

$$\ln I = \ln I_0 - \frac{t}{RC}$$

$$\ln V = \ln V_0 - \frac{t}{RC}$$

In a magnetic field

$$F = Bqv \sin \theta$$

$$F = BIl \sin \theta$$

Faraday's and Lenz's laws

$$\mathcal{E} = \frac{-d(N\phi)}{dt}$$

Nuclear and particle physics

In a magnetic field

$$r = \frac{p}{BQ}$$

Mass-energy

$$\Delta E = c^2 \Delta m$$

DO NOT WRITE IN THIS AREA

DO NOT WRITE IN THIS AREA

DO NOT WRITE IN THIS AREA

