

Please check the examination details below before entering your candidate information

Candidatesurname					Other names							
<b>Pearson Edexcel</b>					Centre Number				Candidate Number			
<b>International Advanced Level</b>					<input type="text"/>				<input type="text"/>			
<b>Monday 11 January 2021</b>												
Afternoon (Time: 1 hour 45 minutes)					Paper Reference <b>WPH14/01</b>							
<b>Physics</b>												
<b>International Advanced Level</b>												
<b>Unit 4: Further Mechanics, Fields and Particles</b>												
<b>You must have:</b> Scientific calculator								Total Marks				

### Instructions

- Use **black** ink or **black** ball-point pen.
- **Fill in the boxes** at the top of this page with your name, centre number and candidate number.
- Answer **all** questions.
- Answer the questions in the spaces provided  
– *there may be more space than you need.*
- **Show all your working out** in calculations and include units where appropriate.

### Information

- The total mark for this paper is 90.
- The marks for **each** question are shown in brackets  
– *use this as a guide as to how much time to spend on each question.*
- In the question marked with an **asterisk** (\*), marks will be awarded for your ability to structure your answer logically showing how the points that you make are related or follow on from each other where appropriate.
- The list of data, formulae and relationships is printed at the end of this booklet.

### Advice

- Read each question carefully before you start to answer it.
- Try to answer every question.
- Check your answers if you have time at the end.

Turn over ►

P67795A

©2021 Pearson Education Ltd.

1/1/1/



  
Pearson

## SECTION A

Answer ALL questions.

For questions 1–10 select one answer from A to D and put a cross in the box ☒.

If you change your mind, put a line through the box ☒ and then mark your new answer with a cross ☒.

1 Which of the following is **not** a vector quantity?

- A electric field strength
- B impulse
- C magnetic flux density
- D work done

(Total for Question 1 = 1 mark)

2 A particle of mass  $m$  has momentum  $p$  and kinetic energy  $E_k$ .  
A second particle of mass  $m/2$  has momentum  $2p$ .

What is the kinetic energy of the second particle?

- A  $E_k/8$
- B  $E_k/2$
- C  $2E_k$
- D  $8E_k$

(Total for Question 2 = 1 mark)

3 In 2016 the element oganesson was added to the periodic table.

One isotope of oganesson has the symbol  ${}_{118}^{294}\text{Og}$ .

Which row of the table shows the number of protons and the number of neutrons in a nucleus of this isotope of oganesson?

	Number of protons	Number of neutrons
<input type="checkbox"/> A	118	176
<input type="checkbox"/> B	118	294
<input type="checkbox"/> C	176	294
<input type="checkbox"/> D	294	118

(Total for Question 3 = 1 mark)



4 A particle has a mass of  $3.17 \times 10^{-27}$  kg.

Which of the following gives the mass in  $\text{GeV}/c^2$ ?

- A  $\frac{3.17 \times 10^{-27} \times 10^9 \times 1.6 \times 10^{-19}}{3.00 \times 10^8}$
- B  $\frac{3.17 \times 10^{-27} \times 10^9 \times 1.6 \times 10^{-19}}{(3.00 \times 10^8)^2}$
- C  $\frac{3.17 \times 10^{-27} \times (3.00 \times 10^8)^2}{1.6 \times 10^{-19}}$
- D  $\frac{3.17 \times 10^{-27} \times (3.00 \times 10^8)^2}{10^9 \times 1.6 \times 10^{-19}}$

(Total for Question 4 = 1 mark)

DO NOT WRITE IN THIS AREA

DO NOT WRITE IN THIS AREA

DO NOT WRITE IN THIS AREA



- 5 An uncharged capacitor, a resistor, a switch and a cell are connected in series as shown.

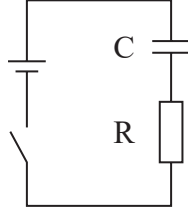

Which of the following shows how the charge stored on the capacitor and the potential difference (p.d.) across the resistor vary with time, after the switch is closed?

	capacitor	resistor
<input type="checkbox"/> A		
<input type="checkbox"/> B		
<input type="checkbox"/> C		
<input type="checkbox"/> D		

(Total for Question 5 = 1 mark)



- 6 A positron and a muon travel at the same speed through a magnetic field. The magnetic field is directed into the page.

Which of the following diagrams best represents the motion of the particles?

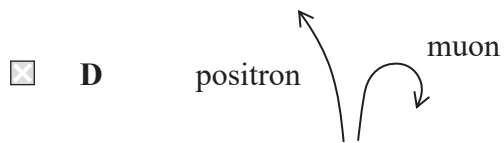
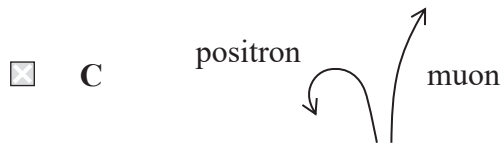
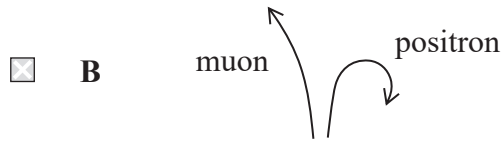
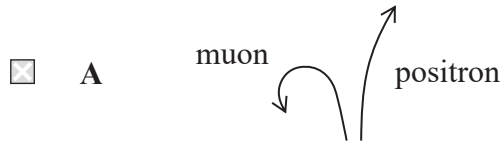

(Total for Question 6 = 1 mark)



7 Point charges of  $2\ \mu\text{C}$  and  $3\ \mu\text{C}$  are placed  $1.2\ \text{m}$  apart as shown.



What is the electric field strength at the point labelled X?

- A  $\frac{2 \times 10^{-6}}{4\pi\epsilon_0(0.4)^2} + \frac{3 \times 10^{-6}}{4\pi\epsilon_0(0.8)^2}$
- B  $\frac{2 \times 10^{-6}}{4\pi\epsilon_0(0.4)^2} - \frac{3 \times 10^{-6}}{4\pi\epsilon_0(0.8)^2}$
- C  $\frac{2 \times 10^{-6}}{4\pi\epsilon_0(0.8)^2} + \frac{3 \times 10^{-6}}{4\pi\epsilon_0(0.4)^2}$
- D  $\frac{2 \times 10^{-6}}{4\pi\epsilon_0(0.8)^2} - \frac{3 \times 10^{-6}}{4\pi\epsilon_0(0.4)^2}$

(Total for Question 7 = 1 mark)

DO NOT WRITE IN THIS AREA

DO NOT WRITE IN THIS AREA

DO NOT WRITE IN THIS AREA



- 8 A wire is held firmly in place between two magnets mounted on top of an electric balance as shown.

The reading on the balance is 1.500 N.

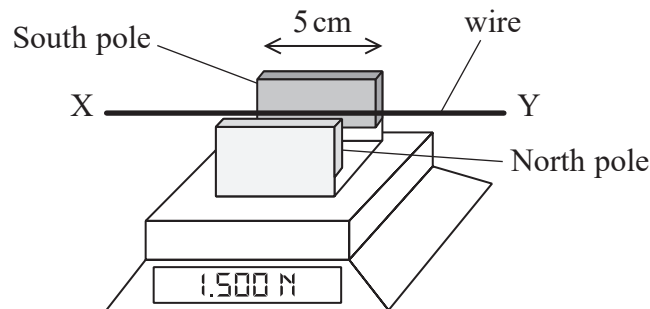

The magnetic flux density between the magnets is 0.07 T.

When the wire is connected to a circuit so there is a current in the wire, the reading on the balance is 1.503 N.

Which of the following gives the current in the wire in ampere and its direction?

- A  $\frac{0.003}{0.07 \times 0.05}$  from X to Y
- B  $\frac{0.003}{0.07 \times 0.05}$  from Y to X
- C  $\frac{0.07 \times 0.05}{0.003}$  from X to Y
- D  $\frac{0.07 \times 0.05}{0.003}$  from Y to X

(Total for Question 8 = 1 mark)



9 A 6 V battery is connected across two parallel metal plates.

Which of the following shows the electric field lines and equipotentials in the region between the plates?

- A
- 
- B
- 
- C
- 
- D
- 

(Total for Question 9 = 1 mark)

10 A charged capacitor is connected across a resistor of resistance  $R$  and the current in the resistor is measured.

A graph of  $\ln(\text{current})$  against time is plotted and the gradient of the graph is determined.

Which of the following gives the capacitance of the capacitor?

- A  $-\text{gradient} \times R$
- B  $\frac{-1}{(\text{gradient} \times R)}$
- C  $\frac{-R}{\text{gradient}}$
- D  $\frac{-\text{gradient}}{R}$

(Total for Question 10 = 1 mark)

TOTAL FOR SECTION A = 10 MARKS



## SECTION B

Answer ALL questions. Write your answers in the spaces provided.

- 11 The diagram shows two capacitors, each of capacitance  $32 \mu\text{F}$ . The capacitors are connected to a battery of e.m.f.  $6.0 \text{ V}$ .

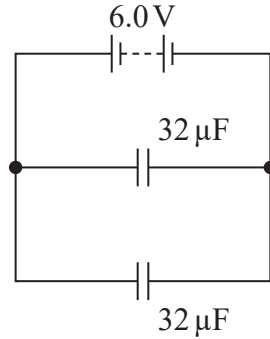

- (a) Calculate the total charge stored by the capacitors.

(2)

Total charge stored = .....

- (b) Calculate the total energy stored by the capacitors.

(2)

Total energy stored = .....

**(Total for Question 11 = 4 marks)**





13 A stationary anti-neutron decays by emitting a positron.

(a) Explain how energy is conserved in this decay.

(2)

(b) The equation shows the decay of an anti-neutron.

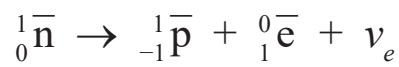

Explain how this equation shows that the decay obeys three conservation laws.

(6)

(Total for Question 13 = 8 marks)



14 Muons are produced by cosmic rays in the Earth's upper atmosphere.

In 1940, Bruno Rossi and David Hall made observations of the decay of these muons.

They measured the number of muons reaching the bottom of a mountain and the number reaching a position 1600 m higher up the mountain.

The muons were travelling at a speed of  $0.994c$ .

Rossi and Hall found that 74% of the muons detected at 1600 m reached the bottom of the mountain. The average lifetime of muons at rest is only  $2.2 \times 10^{-6}$  s, so they suggested that their observations could be explained using ideas from relativity.

(a) Explain whether these observations are consistent with ideas from relativity.

Your answer should include a calculation.

(5)

DO NOT WRITE IN THIS AREA

DO NOT WRITE IN THIS AREA

DO NOT WRITE IN THIS AREA



DO NOT WRITE IN THIS AREA

DO NOT WRITE IN THIS AREA

DO NOT WRITE IN THIS AREA

(b) After muons were discovered in 1936 they were known for many years as mu mesons.

Explain why muons are not described as mesons in the standard model.

(2)

.....

.....

.....

.....

.....

**(Total for Question 14 = 7 marks)**



15 In 1937 scientists at the University of California used high-speed particles from a cyclotron to produce an isotope of phosphorus. This isotope can be used in a treatment for cancer.

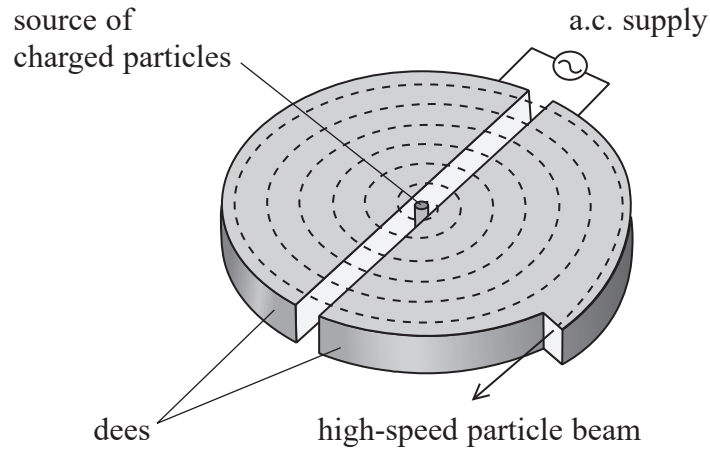

\*(a) Explain the role of electric and magnetic fields in the production of high-speed charged particles by a cyclotron.

(6)

.....

.....

.....

.....

.....

.....

.....

.....

.....

.....

.....

.....

.....

.....

.....

.....

.....

.....

.....

.....

.....

.....

.....

DO NOT WRITE IN THIS AREA

DO NOT WRITE IN THIS AREA

DO NOT WRITE IN THIS AREA



DO NOT WRITE IN THIS AREA

DO NOT WRITE IN THIS AREA

DO NOT WRITE IN THIS AREA

(b) The cyclotron could produce beams of alpha particles with kinetic energy up to 16 MeV.

Calculate the magnetic flux density required by the cyclotron when alpha particles with kinetic energy of 16 MeV are produced.

diameter of cyclotron = 0.94 m

mass of alpha particle =  $6.6 \times 10^{-27}$  kg

(4)

.....

.....

.....

.....

.....

.....

.....

.....

Magnetic flux density = .....

**(Total for Question 15 = 10 marks)**



16 At the Culham Centre for Fusion Energy (CCFE), experiments are carried out on plasmas.

A plasma is an ionised gas which is an electrical conductor. The plasma at CCFE is contained in a doughnut-shaped vessel known as a tokamak.

A current in the plasma is produced by steadily increasing a current in a coil passing through the hole at the centre of the tokamak.

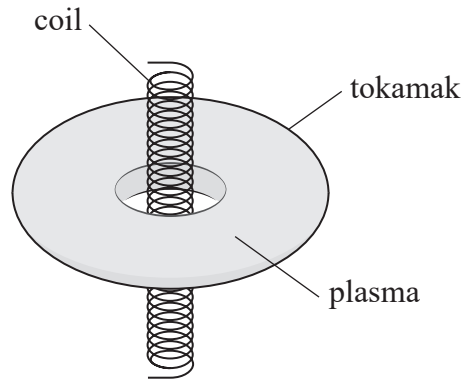

The plasma in the tokamak acts as a single conducting loop around the central coil.

(a) Explain how steadily increasing the current in the central coil produces a current in the plasma.

(4)

DO NOT WRITE IN THIS AREA

DO NOT WRITE IN THIS AREA

DO NOT WRITE IN THIS AREA



DO NOT WRITE IN THIS AREA

DO NOT WRITE IN THIS AREA

DO NOT WRITE IN THIS AREA

(b) The plasma can be considered to be a cylinder of length 13.2 m and cross-sectional area 2.30 m<sup>2</sup>.

(i) Show that the resistance of the plasma is about  $1.9 \times 10^{-7} \Omega$ .

resistivity =  $3.30 \times 10^{-8} \Omega \text{m}$

(2)

(ii) In a particular experiment, the current in the central coil is increased steadily from zero to its maximum value in a time of 25.0 s.  
When the current in the central coil reaches its maximum, the magnetic flux linkage with the plasma loop is 16.9 Wb.

Calculate the heating power produced in the plasma.

(4)

Heating power = .....

**(Total for Question 16 = 10 marks)**



P 6 7 7 9 5 A 0 1 7 3 2

DO NOT WRITE IN THIS AREA

DO NOT WRITE IN THIS AREA

DO NOT WRITE IN THIS AREA

**BLANK PAGE**



- 17 A student carried out experiments on momentum using two table hockey pucks, as shown.



The pucks each contain a small fan, so that they glide across the table on a cushion of air. The mass of the pucks can be varied by attaching small masses.

In each experiment, the student pushed one puck towards a stationary puck.

- (a) In one experiment, the first puck reached a speed of  $0.35 \text{ m s}^{-1}$  after being pushed for a time of  $0.28 \text{ s}$ .

Calculate, using the idea of impulse, the average force used to accelerate the first puck.

mass of puck =  $110 \text{ g}$

(3)

Average force = .....



- (b) In another experiment, the first puck was pushed towards the stationary puck with a speed of  $0.41 \text{ m s}^{-1}$ . The paths of the pucks before and after the collision are shown. The paths are labelled puck 1 and puck 2.

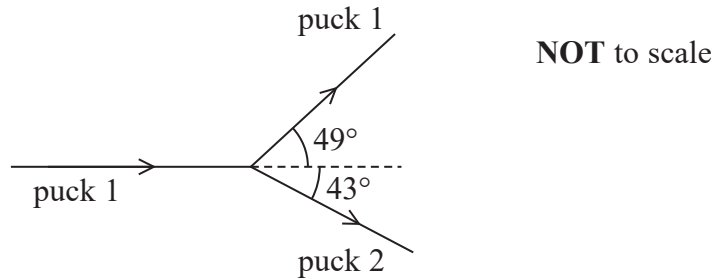

- (i) Calculate the speed of puck 2 after the collision.

mass of puck 1 = 110 g

mass of puck 2 = 130 g

speed of puck 1 after collision =  $0.28 \text{ m s}^{-1}$

(4)

Speed of puck 2 = .....

DO NOT WRITE IN THIS AREA

DO NOT WRITE IN THIS AREA

DO NOT WRITE IN THIS AREA



(ii) Deduce whether this was an elastic collision.

(3)

DO NOT WRITE IN THIS AREA

.....

.....

.....

.....

.....

.....

(c) Explain the assumption made when applying the principle of conservation of momentum to collisions.

(2)

DO NOT WRITE IN THIS AREA

.....

.....

.....

.....

.....

.....

**(Total for Question 17 = 12 marks)**

DO NOT WRITE IN THIS AREA



18 In the early part of the 20th century, experiments were carried out in which alpha particles were directed at thin sheets of metal.

A few alpha particles were deviated through small angles and a very small proportion were reflected back.

(a) The diagram represents an alpha particle reflected back through  $180^\circ$  as it approached the nucleus of a gold atom.

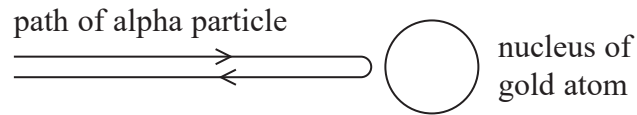

Calculate the maximum acceleration of the alpha particle as it reaches the point of minimum separation from the nucleus. Assume that the gold nucleus remains at rest.

$$\text{speed of alpha particle} = 1.74 \times 10^7 \text{ m s}^{-1}$$

$$\text{mass of alpha particle} = 6.64 \times 10^{-27} \text{ kg}$$

$$\text{atomic number of gold} = 79$$

(5)

Maximum acceleration = .....

DO NOT WRITE IN THIS AREA

DO NOT WRITE IN THIS AREA

DO NOT WRITE IN THIS AREA



DO NOT WRITE IN THIS AREA

DO NOT WRITE IN THIS AREA

DO NOT WRITE IN THIS AREA

(b) The diagram represents the path of an alpha particle with the same initial speed as in (a) that is deflected through a smaller angle.

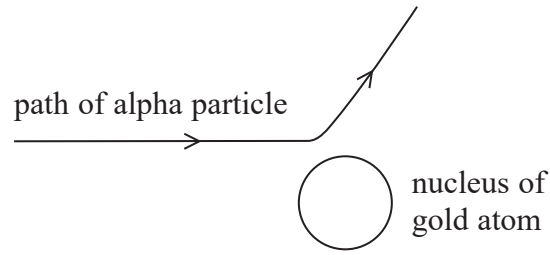

Explain whether the maximum acceleration would be the same as for the alpha particle reflected back through  $180^\circ$ .

(4)

.....

.....

.....

.....

.....

.....

.....

.....

.....

.....

.....

**(Total for Question 18 = 9 marks)**



19 In 1909 Robert Millikan carried out experiments to determine the magnitude of the charge on an electron.

His experiments involved the motion of small, electrically charged droplets of oil between two charged metal plates.

Some students carried out a similar experiment in a school laboratory.

(a) The terminal velocity  $v$  of an oil droplet was measured as it fell a known distance in air when the plates were uncharged. Stokes' law was then used to determine the radius  $r$  of the oil droplet. Upthrust was ignored.

(i) Show that  $r = \sqrt{\frac{9\eta v}{2\rho g}}$

$\eta$  = viscosity of air

$\rho$  = density of oil

(3)

(ii) For a particular oil droplet, the terminal velocity was measured to be  $5.35 \times 10^{-4} \text{ m s}^{-1}$ .

Calculate the radius of this oil droplet.

$\eta = 1.86 \times 10^{-5} \text{ Pa s}$

$\rho = 904 \text{ kg m}^{-3}$

(2)

Radius = .....

DO NOT WRITE IN THIS AREA

DO NOT WRITE IN THIS AREA

DO NOT WRITE IN THIS AREA



- (iii) A potential difference (p.d.) was applied across the plates and adjusted until a charged oil droplet was stationary between them.

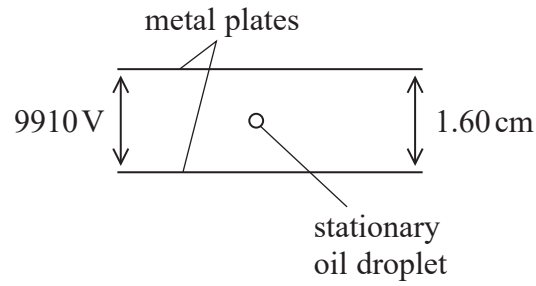

Calculate the charge on the oil droplet.

mass of oil droplet =  $3.03 \times 10^{-14}$  kg

p.d. = 9910 V

separation of plates = 1.60 cm

(4)

Charge = .....



- (b) The students repeated the experiment for a large number of oil droplets. The graph shows the number of oil droplets with each measured charge.

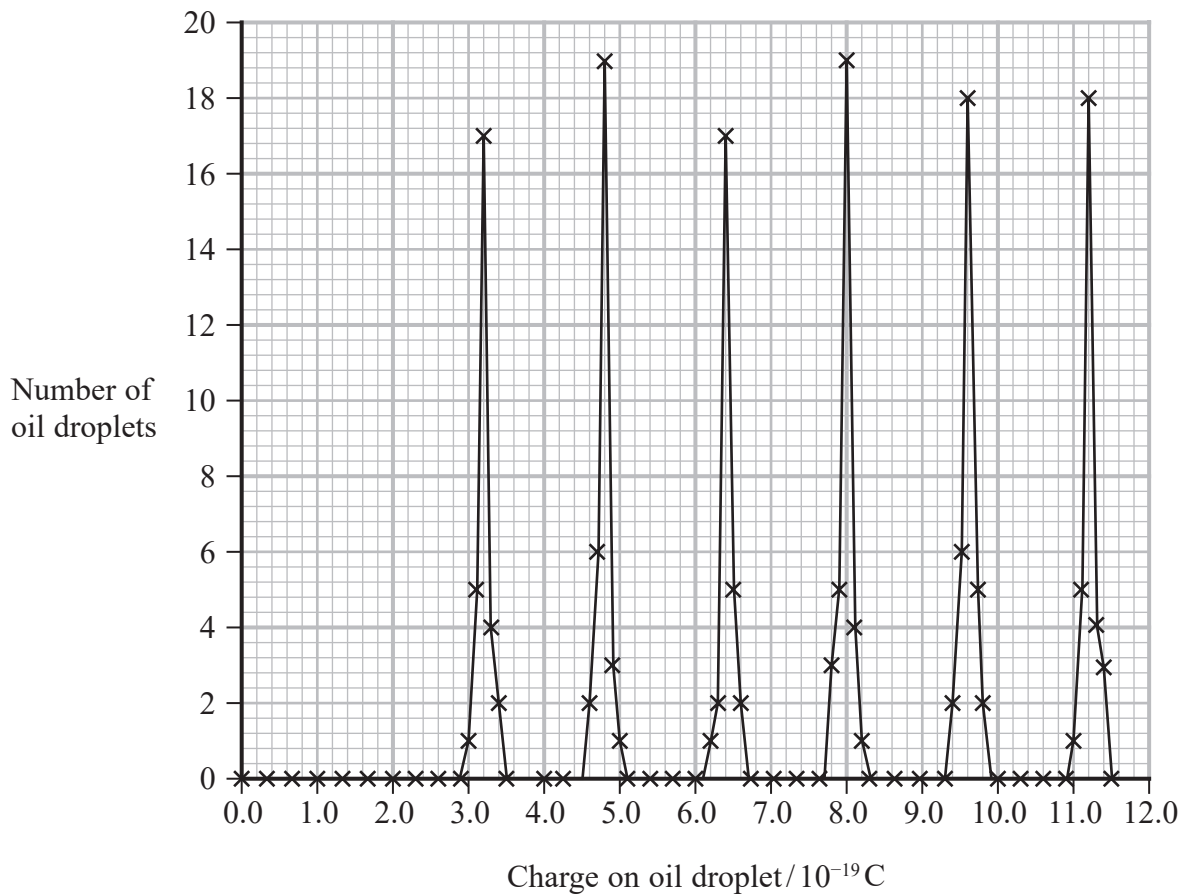

The teacher states that charge can only be transferred in integer multiples of  $1.6 \times 10^{-19}$  C.

Explain the extent to which the students' results support this statement.

(3)

.....

.....

.....

.....

.....

.....

.....



- (c) In 1909 Millikan concluded that the charge on the electron was  $1.592 \times 10^{-19} \text{ C}$  whereas the accepted value today is  $1.602 \times 10^{-19} \text{ C}$ . This was because the value for the viscosity of air used by Millikan was incorrect.

Deduce whether the value for the viscosity used by Millikan was too large or too small.

(3)

(Total for Question 19 = 15 marks)

**TOTAL FOR SECTION B = 80 MARKS**

**TOTAL FOR PAPER = 90 MARKS**

DO NOT WRITE IN THIS AREA

DO NOT WRITE IN THIS AREA

DO NOT WRITE IN THIS AREA



**List of data, formulae and relationships**

Acceleration of free fall	$g = 9.81 \text{ m s}^{-2}$	(close to Earth's surface)
Boltzmann constant	$k = 1.38 \times 10^{-23} \text{ J K}^{-1}$	
Electron charge	$e = -1.60 \times 10^{-19} \text{ C}$	
Electron mass	$m_e = 9.11 \times 10^{-31} \text{ kg}$	
Electronvolt	$1 \text{ eV} = 1.60 \times 10^{-19} \text{ J}$	
Gravitational constant	$G = 6.67 \times 10^{-11} \text{ N m}^2 \text{ kg}^{-2}$	
Gravitational field strength	$g = 9.81 \text{ N kg}^{-1}$	(close to Earth's surface)
Permittivity of free space	$\epsilon_0 = 8.85 \times 10^{-12} \text{ F m}^{-1}$	
Coulomb's law constant	$k = 1/4\pi\epsilon_0$ $= 8.99 \times 10^9 \text{ N m}^2 \text{ C}^{-2}$	
Planck constant	$h = 6.63 \times 10^{-34} \text{ J s}$	
Proton mass	$m_p = 1.67 \times 10^{-27} \text{ kg}$	
Speed of light in a vacuum	$c = 3.00 \times 10^8 \text{ m s}^{-1}$	
Stefan-Boltzmann constant	$\sigma = 5.67 \times 10^{-8} \text{ W m}^{-2} \text{ K}^{-4}$	
Unified atomic mass unit	$u = 1.66 \times 10^{-27} \text{ kg}$	

**Unit 1***Mechanics*

Kinematic equations of motion

$$s = \frac{(u + v)t}{2}$$

$$v = u + at$$

$$s = ut + \frac{1}{2}at^2$$

$$v^2 = u^2 + 2as$$

## Forces

$$\Sigma F = ma$$

$$g = \frac{F}{m}$$

$$W = mg$$

## Momentum

$$p = mv$$

## Moment of force

$$\text{moment} = Fx$$

## Work and energy

$$\Delta W = F\Delta s$$

$$E_k = \frac{1}{2}mv^2$$

$$\Delta E_{\text{grav}} = mg\Delta h$$

## Power

$$P = \frac{E}{t}$$

$$P = \frac{W}{t}$$

DO NOT WRITE IN THIS AREA

DO NOT WRITE IN THIS AREA

DO NOT WRITE IN THIS AREA



Efficiency

$$\text{efficiency} = \frac{\text{useful energy output}}{\text{total energy input}}$$

$$\text{efficiency} = \frac{\text{useful power output}}{\text{total power input}}$$

*Materials*

Density

$$\rho = \frac{m}{V}$$

Stokes' law

$$F = 6\pi\eta rv$$

Hooke's law

$$\Delta F = k\Delta x$$

Elastic strain energy

$$\Delta E_{\text{el}} = \frac{1}{2} F\Delta x$$

Young modulus

$$E = \frac{\sigma}{\varepsilon} \text{ where}$$

$$\text{Stress } \sigma = \frac{F}{A}$$

$$\text{Strain } \varepsilon = \frac{\Delta x}{x}$$

DO NOT WRITE IN THIS AREA

DO NOT WRITE IN THIS AREA

DO NOT WRITE IN THIS AREA



**Unit 2***Waves*

Wave speed

$$v = f\lambda$$

Speed of a transverse wave on a string

$$v = \sqrt{\frac{T}{\mu}}$$

Intensity of radiation

$$I = \frac{P}{A}$$

Refractive index

$$n_1 \sin \theta_1 = n_2 \sin \theta_2$$

$$n = \frac{c}{v}$$

Critical angle

$$\sin C = \frac{1}{n}$$

Diffraction grating

$$n\lambda = d \sin \theta$$

*Electricity*

Potential difference

$$V = \frac{W}{Q}$$

Resistance

$$R = \frac{V}{I}$$

Electrical power, energy

$$P = VI$$

$$P = I^2R$$

$$P = \frac{V^2}{R}$$

$$W = VIt$$

Resistivity

$$R = \frac{\rho l}{A}$$

Current

$$I = \frac{\Delta Q}{\Delta t}$$

$$I = nqvA$$

Resistors in series

$$R = R_1 + R_2 + R_3$$

Resistors in parallel

$$\frac{1}{R} = \frac{1}{R_1} + \frac{1}{R_2} + \frac{1}{R_3}$$

*Particle nature of light*

Photon model

$$E = hf$$

Einstein's photoelectric equation

$$hf = \phi + \frac{1}{2}mv_{\max}^2$$

de Broglie wavelength

$$\lambda = \frac{h}{p}$$

DO NOT WRITE IN THIS AREA

DO NOT WRITE IN THIS AREA

DO NOT WRITE IN THIS AREA



**Unit 4***Mechanics*

Impulse

$$F\Delta t = \Delta p$$

Kinetic energy of a  
non-relativistic particle

$$E_k = \frac{p^2}{2m}$$

motion in a circle

$$v = \omega r$$

$$T = \frac{2\pi}{\omega}$$

$$a = \frac{v^2}{r}$$

$$a = r\omega^2$$

Centripetal force

$$F = ma = \frac{mv^2}{r}$$

$$F = m\omega^2 r$$

*Electric and magnetic fields*

Electric field

$$E = \frac{F}{Q}$$

Coulomb's law

$$F = \frac{Q_1 Q_2}{4\pi\epsilon_0 r^2}$$

$$E = \frac{Q}{4\pi\epsilon_0 r^2}$$

$$E = \frac{V}{d}$$

Electrical Potential

$$V = \frac{Q}{4\pi\epsilon_0 r}$$

Capacitance

$$C = \frac{Q}{V}$$

Energy stored in capacitor

$$W = \frac{1}{2} QV$$

$$W = \frac{1}{2} CV^2$$

$$W = \frac{1}{2} \frac{Q^2}{C}$$

Capacitor discharge

$$Q = Q_0 e^{-t/RC}$$

DO NOT WRITE IN THIS AREA

DO NOT WRITE IN THIS AREA

DO NOT WRITE IN THIS AREA



Resistor capacitor discharge

$$I = I_0 e^{-t/RC}$$

$$V = V_0 e^{-t/RC}$$

$$\ln Q = \ln Q_0 - \frac{t}{RC}$$

$$\ln I = \ln I_0 - \frac{t}{RC}$$

$$\ln V = \ln V_0 - \frac{t}{RC}$$

In a magnetic field

$$F = Bqv \sin \theta$$

$$F = BIl \sin \theta$$

Faraday's and Lenz's laws

$$\mathcal{E} = \frac{-d(N\phi)}{dt}$$

*Nuclear and particle physics*

In a magnetic field

$$r = \frac{p}{BQ}$$

Mass-energy

$$\Delta E = c^2 \Delta m$$

DO NOT WRITE IN THIS AREA

DO NOT WRITE IN THIS AREA

DO NOT WRITE IN THIS AREA

