

Write your name here

Surname

Other names

Edexcel Certificate

Centre Number

Candidate Number

**Edexcel
International GCSE**

--	--	--	--	--

--	--	--	--

Mathematics A

Paper 1F

**Foundation Tier**

Friday 11 January 2013 – Morning

Time: 2 hours

Paper Reference

**4MA0/1F
KMA0/1F****You must have:**

Ruler graduated in centimetres and millimetres, protractor, compasses, pen, HB pencil, eraser, calculator. Tracing paper may be used.

Total Marks

Instructions

- Use **black** ink or ball-point pen.
- **Fill in the boxes** at the top of this page with your name, centre number and candidate number.
- Answer **all** questions.
- Without sufficient working, correct answers may be awarded no marks.
- Answer the questions in the spaces provided
– *there may be more space than you need.*
- **Calculators may be used.**
- You must **NOT** write anything on the formulae page.
Anything you write on the formulae page will gain **NO** credit.

Information

- The total mark for this paper is 100.
- The marks for **each** question are shown in brackets
– *use this as a guide as to how much time to spend on each question.*

Advice

- Read each question carefully before you start to answer it.
- Check your answers if you have time at the end.

Turn over ►

P41035A

©2013 Pearson Education Ltd.

6/6/5/6/6/

**PEARSON**

International GCSE MATHEMATICS

FORMULAE SHEET – FOUNDATION TIER

Pythagoras' Theorem
 $a^2 + b^2 = c^2$

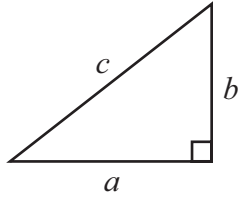

Area of a trapezium = $\frac{1}{2}(a + b)h$

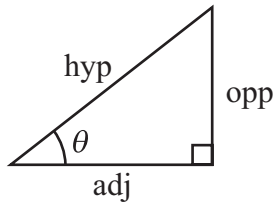
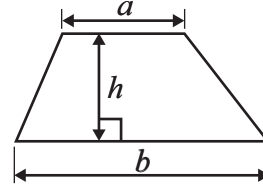

adj = hyp \times cos θ
 opp = hyp \times sin θ
 opp = adj \times tan θ

Volume of prism = area of cross section \times length

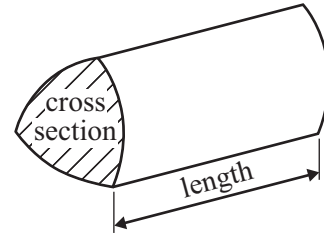

or $\sin \theta = \frac{\text{opp}}{\text{hyp}}$

$\cos \theta = \frac{\text{adj}}{\text{hyp}}$

$\tan \theta = \frac{\text{opp}}{\text{adj}}$

Circumference of circle = $2\pi r$

Area of circle = πr^2

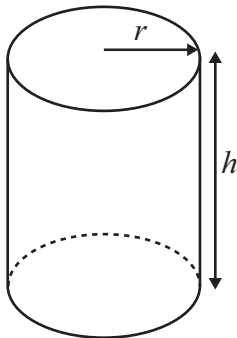

Volume of cylinder = $\pi r^2 h$

Curved surface area of cylinder = $2\pi r h$

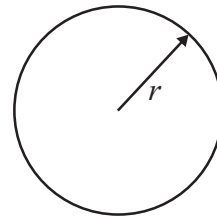

Answer ALL NINETEEN questions.

Write your answers in the spaces provided.

You must write down all the stages in your working.

1 The table shows the heights of five mountains.

Mountain	Height (metres)
Kilimanjaro	5895
Mount McKinley	6194
Shispar	7612
K2	8611
Mont Blanc	4810

(a) Write down the name of the highest of the five mountains.

.....
(1)

(b) Write the number 6194 in words.

.....
(1)

(c) Write the number 5895 correct to the nearest hundred.

.....
(1)

(d) Which number in the table is a multiple of 3?

.....
(1)

(e) What is the difference in height between Kilimanjaro and Mont Blanc?

..... m
(1)

(Total for Question 1 is 5 marks)



- 2 The bar chart shows the percentage of the world's oil used by each of five regions in 2009.

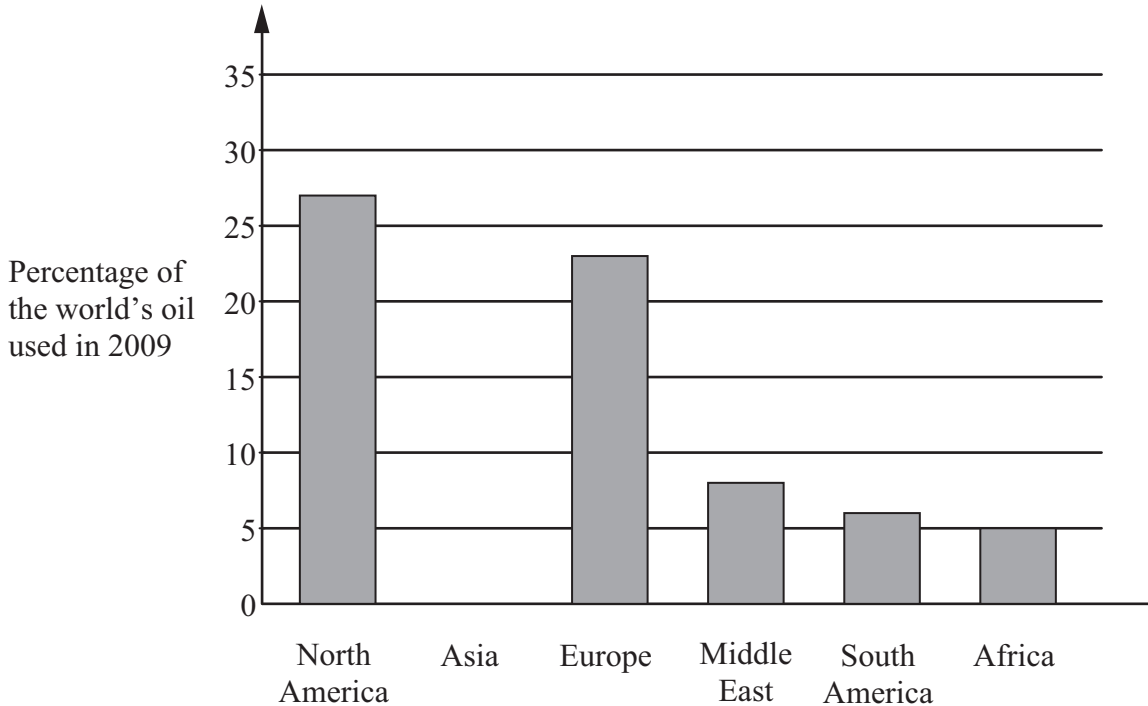

- (a) Write down the percentage of the world's oil used by Africa.

..... %
(1)

- (b) Write down the percentage of the world's oil used by North America.

..... %
(1)

- (c) (i) Write down the name of the region which used 8% of the world's oil.

.....

- (ii) Change 8% to a fraction.
Give your fraction in its simplest form.

.....
(3)

In 2009, the percentage of the world's oil used by Asia was 31%.

- (d) Draw a bar on the bar chart to show this information.

(1)

(Total for Question 2 is 6 marks)



3 (a) Write down the value of the 3 in the number 7.432

.....
(1)

(b) Round 7.432 to the nearest whole number.

.....
(1)

(c) Write down the number which is exactly halfway between 0.7 and 0.8

.....
(1)

(d) Write these numbers in order of size.
Start with the smallest number.

0.14

0.35

0.4

0.07

0.306

.....
(1)

(e) Write 0.31 as a fraction.

.....
(1)

(Total for Question 3 is 5 marks)

Do NOT write in this space.



4 Here is a list of six numbers.

2

3

5

6

7

8

From the list, write a number in each box, to make each statement correct.

(i) + x = 61

(ii) - ÷ = 0

(Total for Question 4 is 2 marks)

Do NOT write in this space.



5 Here is a sequence of patterns made from buttons.

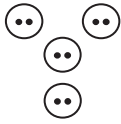

Pattern
number 1

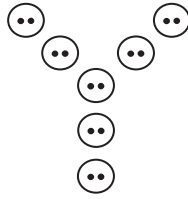

Pattern
number 2

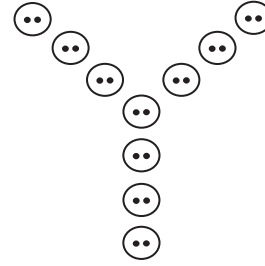

Pattern
number 3

(a) In the space below, draw Pattern number 4

(1)

This rule can be used to find the number of buttons in a pattern.

Multiply the Pattern number by 3 and then add 1 to the result.

(b) Work out the number of buttons in Pattern number 8

.....
(2)

(c) Work out the Pattern number of the pattern with exactly 55 buttons.

.....
(2)

(Total for Question 5 is 5 marks)



- 6 The diagram shows 7 shapes, **A**, **B**, **C**, **D**, **E**, **F** and **G**, on a centimetre square grid.

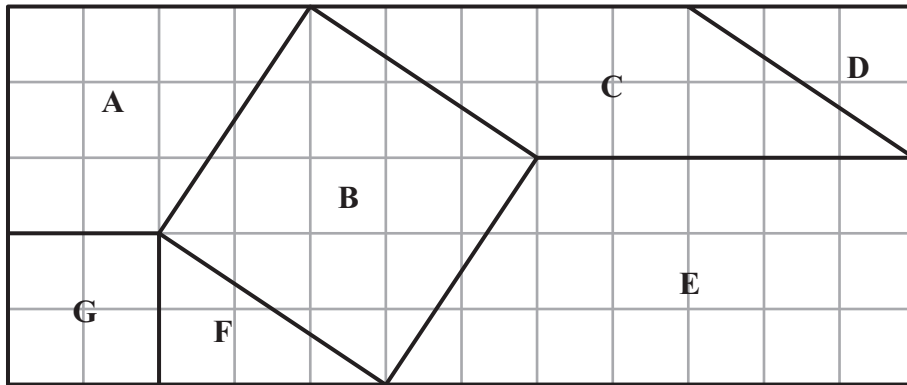

- (a) What is the mathematical name of shape **E**?

.....
(1)

- (b) Write down the letters of the two shapes which are congruent.

..... and
(1)

- (c) Mark an obtuse angle on one of the shapes.
Label your angle x .

.....
(1)

- (d) How many lines of symmetry has shape **B**?

.....
(1)

- (e) Work out the area of shape **C**.

..... cm^2
(2)

(Total for Question 6 is 6 marks)



- 7 BCE and FCD are straight lines.
 $CD = CE$

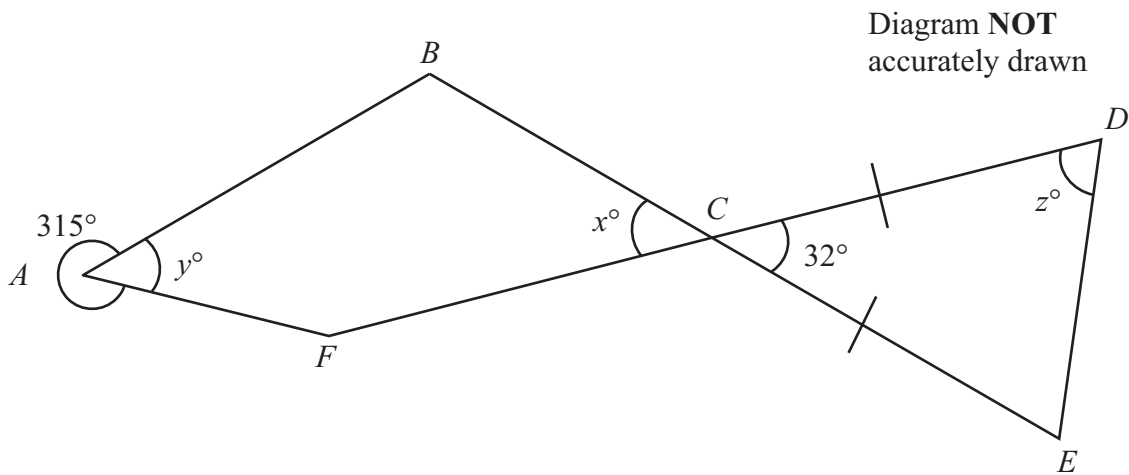

- (a) (i) Find the value of x .

$$x = \dots\dots\dots$$

- (ii) Give a reason for your answer.

(2)

- (b) (i) Work out the value of y .

$$y = \dots\dots\dots$$

- (ii) Give a reason for your answer.

(2)

- (c) Work out the value of z .

$$z = \dots\dots\dots$$

(2)

(Total for Question 7 is 6 marks)



- 8 10 students took a maths test.
Here are their scores.

25 37 22 19 37 43 30 15 34 36

- (a) Work out the range.

.....
(2)

- (b) Work out the median.

.....
(2)

- (c) Later, the score of 15 was changed to 18

- (i) Will the median increase, decrease or stay the same?

-
(ii) Give a reason for your answer.

.....
.....
(2)

(Total for Question 8 is 6 marks)

Do NOT write in this space.



9 (a) Find the value of $12 \div (2 - 5)$

.....
(1)

(b) Find the value of 6^4

.....
(1)

(c) Write down the prime number whose value is nearest to 33

.....
(1)

(d) Find the cube root of 343

.....
(1)

(Total for Question 9 is 4 marks)

10 (a) Solve $6x + 5 = 20$
Show clear algebraic working.

$x =$
(2)

(b) Solve $4(2y - 5) = 30$
Show clear algebraic working.

$y =$
(3)

(Total for Question 10 is 5 marks)



11 Nicole went on holiday from Paris to South Africa.
The exchange rate was 1 euro = 9.54 Rand.

(a) Nicole changed 600 euros into Rand.
How many Rand did she get?

..... Rand
(2)

(b) Her flight took off at 20 30 Paris time and landed at 08 15 Paris time the next day.
How long was the flight in hours and minutes?

..... hours minutes
(3)

Nicole returned to Paris after her holiday.
The exchange rate had changed to 1 euro = 9.80 Rand.

(c) Nicole changed 1470 Rand into euros.
How many euros did she get?

..... euros
(2)

(Total for Question 11 is 7 marks)



12 (a) $W = 3x + 4y$

Work out the value of W when $x = 2$ and $y = 6$

.....
(2)

(b) Simplify

(i) $m \times n \times 7$

(ii) $\frac{12y^4}{2}$

(iii) $7g - 10h + 2g + 4h$

.....
(4)

(c) Multiply out $3(2t - 4)$

.....
(1)

(Total for Question 12 is 7 marks)



13 Here is a biased 5-sided spinner.

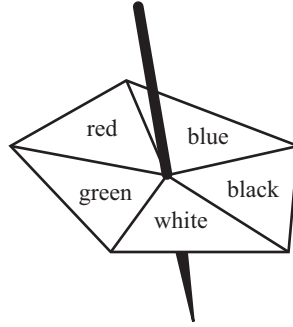

When the spinner is spun, it can land on red, blue, black, white or green.
The probability that it lands on red, blue, black or white is given in the table.

Colour	red	blue	black	white	green
Probability	0.18	0.20	0.23	0.22	

George spins the spinner once.

(a) Work out the probability that the spinner lands on green.

.....
(2)

Heena spins the spinner 40 times.

(b) Work out an estimate for the number of times the spinner lands on blue.

.....
(2)

(Total for Question 13 is 4 marks)

Do NOT write in this space.



- 14 Joseph travels to work each day by train.
The weekly cost of his train journey is £45
Joseph's weekly pay is £625

(a) Work out 45 as a percentage of 625

..... %
(2)

(b) The weekly cost of his train journey increases by 8%.

Increase £45 by 8%.

£
(3)

(c) Joseph's weekly pay increases to £640

Calculate the percentage increase from 625 to 640

..... %
(3)

(d) Joseph decides to cycle to work.

He cycles 18 km to work.

His journey to work takes 1 hour 20 minutes.

Calculate his average speed in kilometres per hour.

..... km/h
(3)

(Total for Question 14 is 11 marks)



15

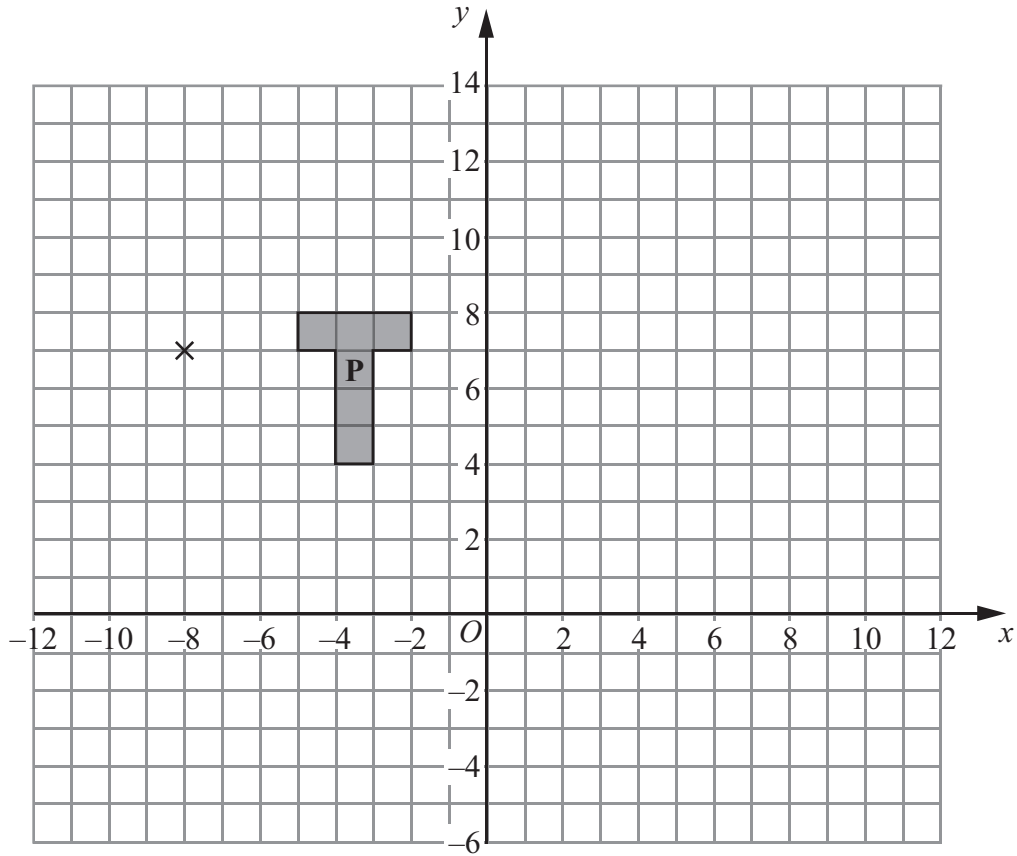

(a) On the grid, enlarge shape **P** with scale factor 3 and centre $(-8, 7)$.

Label the new shape **Q**.

(3)

(b) On the grid, rotate shape **P** through 90° clockwise about the point $(-8, 7)$.

Label the new shape **R**.

(2)

(Total for Question 15 is 5 marks)

16 Solve the simultaneous equations $y - 2x = 6$

$$y + 2x = 0$$

Show clear algebraic working.

$$x = \dots\dots\dots$$

$$y = \dots\dots\dots$$

(Total for Question 16 is 3 marks)



17 A school has 60 teachers.

The table shows information about the distances, in km, the teachers travel to school each day.

Distance (d km)	Frequency
$0 < d \leq 5$	12
$5 < d \leq 10$	6
$10 < d \leq 15$	4
$15 < d \leq 20$	6
$20 < d \leq 25$	14
$25 < d \leq 30$	18

(a) Write down the modal class.

.....
(1)

(b) Work out an estimate for the total distance travelled to school by the 60 teachers each day.

..... km
(3)

(Total for Question 17 is 4 marks)

18 (i) Solve the inequalities $-2 < x + 2 \leq 5$

(ii) On the number line, represent the solution to part (i).

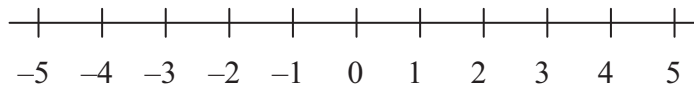

(Total for Question 18 is 4 marks)

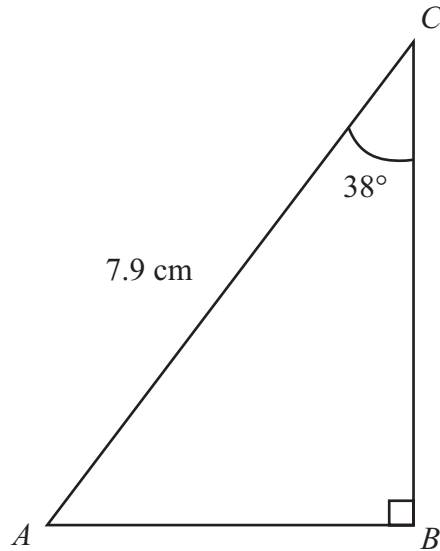

19

Diagram **NOT**
accurately drawn ABC is a triangle. $AC = 7.9$ cmAngle $B = 90^\circ$ Angle $C = 38^\circ$ (a) Calculate the length of BC .

Give your answer correct to 3 significant figures.

..... cm

(3)

(b) The size of angle C is 38° , correct to 2 significant figures.(i) Write down the lower bound of the size of angle C .

o

.....

(ii) Write down the upper bound of the size of angle C .

o

.....

(2)

(Total for Question 19 is 5 marks)

TOTAL FOR PAPER IS 100 MARKS

BLANK PAGE

Do NOT write on this page.



BLANK PAGE

Do NOT write on this page.

