

Write your name here							
Surname			Other names				
Pearson Edexcel Certificate Pearson Edexcel International GCSE		Centre Number			Candidate Number		
		<input style="width: 20px; height: 20px;" type="text"/> <input style="width: 20px; height: 20px;" type="text"/> <input style="width: 20px; height: 20px;" type="text"/> <input style="width: 20px; height: 20px;" type="text"/> <input style="width: 20px; height: 20px;" type="text"/>			<input style="width: 20px; height: 20px;" type="text"/> <input style="width: 20px; height: 20px;" type="text"/> <input style="width: 20px; height: 20px;" type="text"/> <input style="width: 20px; height: 20px;" type="text"/>		
<h1 style="margin: 0;">Mathematics A</h1> <h2 style="margin: 0;">Paper 2F</h2>							
							
					Foundation Tier		
Thursday 9 June 2016 – Morning Time: 2 hours				Paper Reference 4MA0/2F KMA0/2F			
You must have: Ruler graduated in centimetres and millimetres, protractor, compasses, pen, HB pencil, eraser, calculator. Tracing paper may be used.					Total Marks <div style="border: 1px solid black; width: 100%; height: 40px;"></div>		

Instructions

- Use **black** ink or ball-point pen.
- **Fill in the boxes** at the top of this page with your name, centre number and candidate number.
- Answer **all** questions.
- Without sufficient working, correct answers may be awarded no marks.
- Answer the questions in the spaces provided
– *there may be more space than you need.*
- **Calculators may be used.**
- You must **NOT** write anything on the formulae page.
Anything you write on the formulae page will gain NO credit.

Information

- The total mark for this paper is 100.
- The marks for **each** question are shown in brackets
– *use this as a guide as to how much time to spend on each question.*

Advice

- Read each question carefully before you start to answer it.
- Check your answers if you have time at the end.

Turn over ►

P45865A

©2016 Pearson Education Ltd.

1/1/1/1/1/



PEARSON

International GCSE MATHEMATICS
FORMULAE SHEET – FOUNDATION TIER

Pythagoras' Theorem
 $a^2 + b^2 = c^2$

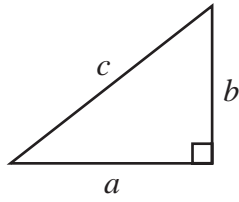

Area of a trapezium = $\frac{1}{2}(a + b)h$

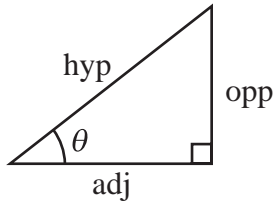
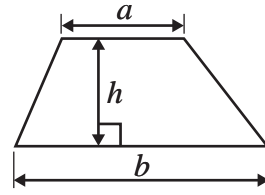

$$\begin{aligned} \text{adj} &= \text{hyp} \times \cos \theta \\ \text{opp} &= \text{hyp} \times \sin \theta \\ \text{opp} &= \text{adj} \times \tan \theta \end{aligned}$$

Volume of prism = area of cross section \times length

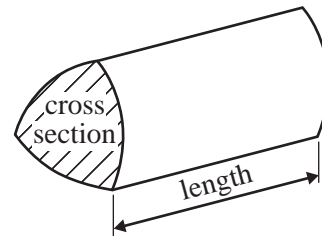

$$\text{or } \sin \theta = \frac{\text{opp}}{\text{hyp}}$$

$$\cos \theta = \frac{\text{adj}}{\text{hyp}}$$

$$\tan \theta = \frac{\text{opp}}{\text{adj}}$$

Circumference of circle = $2\pi r$

Area of circle = πr^2

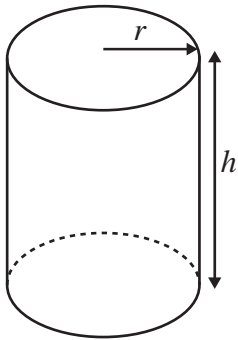

Volume of cylinder = $\pi r^2 h$

Curved surface area
of cylinder = $2\pi r h$

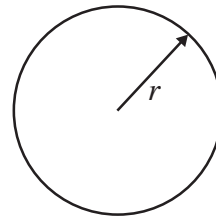

DO NOT WRITE IN THIS AREA

DO NOT WRITE IN THIS AREA

DO NOT WRITE IN THIS AREA



DO NOT WRITE IN THIS AREA

DO NOT WRITE IN THIS AREA

DO NOT WRITE IN THIS AREA

Answer ALL TWENTY TWO questions.

Write your answers in the spaces provided.

You must write down all the stages in your working.

1

10	13	16	21	27	30	33	36
----	----	----	----	----	----	----	----

(a) From the numbers in the box, write down

(i) a multiple of 7

.....

(ii) a factor of 90

.....

(iii) a prime number

.....

(iv) a square number

.....

(v) a cube number

.....

(5)

Two of the numbers in the box give 20 when written correct to the nearest 10

(b) Write down these two numbers.

..... and

(1)

Two of the numbers in the box give 429 when multiplied together.

(c) Write down these two numbers.

..... and

(1)

(Total for Question 1 is 7 marks)



- 2 The bar chart shows the number of gold medals won by each of five countries at the 2014 Winter Olympic Games.

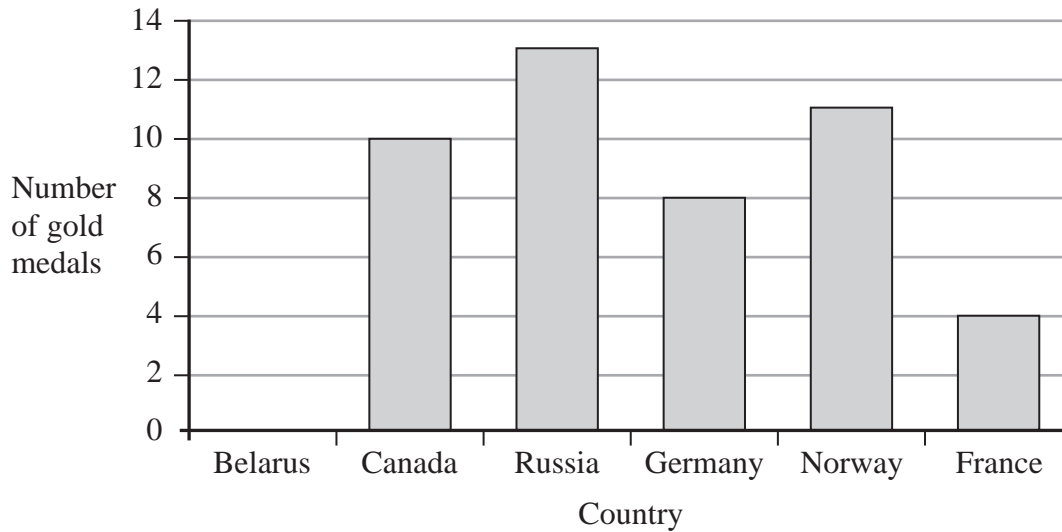

- (a) How many gold medals were won by Germany?

.....
(1)

- (b) Which country won 11 gold medals?

.....
(1)

Belarus won 5 gold medals.

- (c) Draw a bar on the bar chart to show this information.

.....
(1)

Russia won more gold medals than Germany.

- (d) How many more?

.....
(1)

- (e) Find the ratio of the number of gold medals won by Canada to the number of gold medals won by France.

Give your ratio in its simplest form.

.....
(2)

(Total for Question 2 is 6 marks)



- 3 (a) Write down the mathematical name of this 3-D shape.

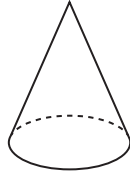

.....
(1)

- (b) (i) Write down the mathematical name of this 3-D shape.

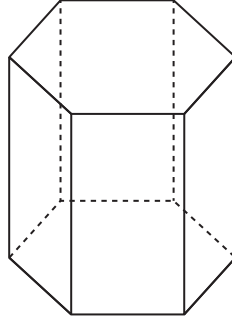

- (ii) How many vertices has this shape?

- (iii) How many edges has this shape?

.....
.....
.....
(3)

Here is a solid prism made from centimetre cubes.

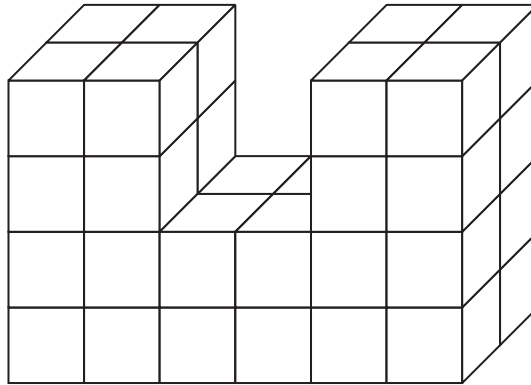

Diagram **NOT**
accurately drawn

- (c) Work out the volume of the prism.

..... cm³
(2)

(Total for Question 3 is 6 marks)



- 4 The table shows the daytime highest temperature and the daytime lowest temperature for each of five places in Germany on one day in December.

	Daytime highest temperature	Daytime lowest temperature
Freiburg	6°C	1°C
Munich	4°C	-2°C
Oberstdorf	4°C	-5°C
Stuttgart	5°C	0°C
Zugspitze	-7°C	-12°C

Here are the daytime lowest temperatures in °C

1 -2 -5 0 -12

- (a) Write these numbers in order of size.
Start with the smallest number.

.....
(1)

- (b) What temperature is halfway between 4°C and -2°C?

..... °C
(1)

- (c) What temperature is 10°C lower than the daytime highest temperature in Munich?

..... °C
(1)

- (d) For which place in the table is there the greatest difference between the daytime highest temperature and the daytime lowest temperature?

.....
(1)

(Total for Question 4 is 4 marks)

DO NOT WRITE IN THIS AREA

DO NOT WRITE IN THIS AREA

DO NOT WRITE IN THIS AREA



- 5 The diagram shows a quadrilateral $ABCD$ on a centimetre grid.

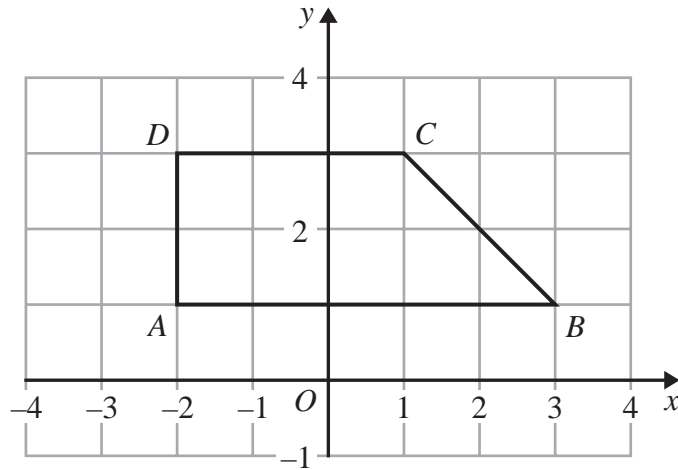

- (a) Write down the coordinates of

(i) point B ,

(.....,) (2)

(ii) point D .

(.....,) (2)

- (b) Write down the equation of the line AB .

..... (1)

- (c) Work out the area of quadrilateral $ABCD$.

..... cm^2 (1)

(Total for Question 5 is 4 marks)



6 Sophia buys

2 balls of wool
 a knitting pattern for \$2.95
 knitting needles for \$4.99

The total cost is \$19.52

The cost of each ball of wool is the same.

Work out the cost of one ball of wool.

\$.....

(Total for Question 6 is 3 marks)

7 Here is a number machine.

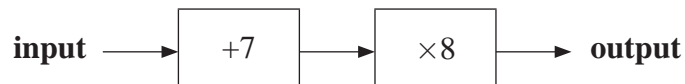

(a) Work out the output when the input is 5

.....
 (1)

(b) Work out the input when the output is 136

.....
 (1)

(Total for Question 7 is 2 marks)



- 8 The clock face shows the time in the **afternoon** when Jacques left school.

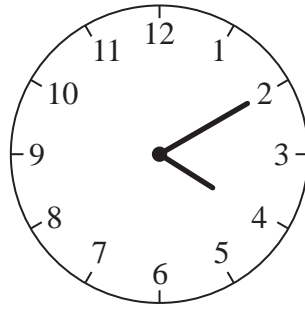

- (a) Write down this time using the 24-hour clock.

.....
(1)

Jacques took 55 minutes to get home from school.

- (b) At what time did Jacques get home from school?

.....
(1)

Later that evening Jacques did his homework.

He started his homework at 18 35

He did not stop until he finished his homework at 20 15

- (c) How long did it take Jacques to do his homework?
Give your answer in minutes.

..... minutes
(2)

(Total for Question 8 is 4 marks)



- 9 The pie chart shows information about the favourite film type chosen by each of the students at a sixth form college.

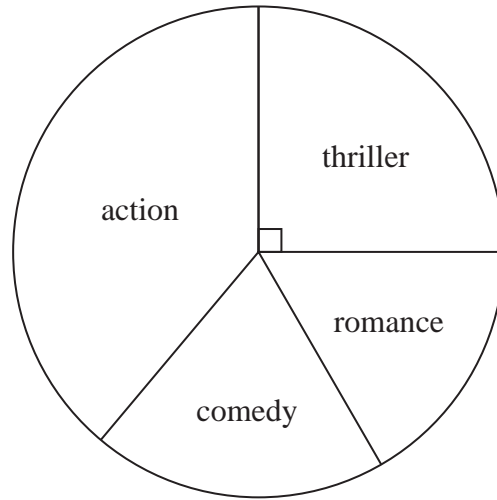

135 students chose “thriller” as their favourite film type.

- (a) Work out how many students there are at the sixth form college.

.....
(2)

- (b) By measuring the appropriate angle, work out how many students chose “action” as their favourite film type.

.....
(3)

(Total for Question 9 is 5 marks)

DO NOT WRITE IN THIS AREA

DO NOT WRITE IN THIS AREA

DO NOT WRITE IN THIS AREA



10 Amit has two fair spinners, spinner **A** and spinner **B**.

Spinner **A** has three sections, numbered 1, 2 and 4

Spinner **B** has four sections, numbered 1, 2, 3 and 5

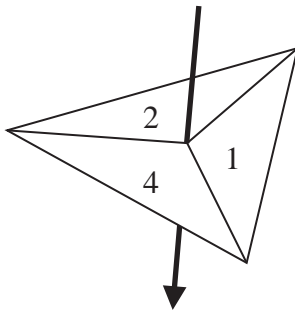

Spinner **A**

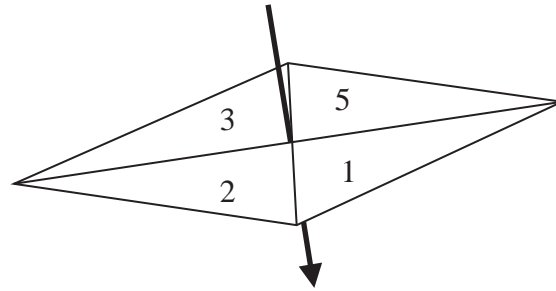

Spinner **B**

Amit spins each spinner once.

He adds together the number that spinner **A** lands on and the number that spinner **B** lands on to find the total.

- (a) Complete the table to show all possible totals.
Four totals have been done for you.

	1	2	3	5
1	2	3		
2			5	
4				9

(2)

(b) Find the probability that the total is

- (i) 5

.....

- (ii) an even number.

.....

(2)

(Total for Question 10 is 4 marks)

DO NOT WRITE IN THIS AREA

DO NOT WRITE IN THIS AREA

DO NOT WRITE IN THIS AREA



- 11** Write these fractions in order of size.
Start with the smallest fraction.

$$\frac{2}{3} \quad \frac{3}{5} \quad \frac{7}{10} \quad \frac{5}{8}$$

.....
(Total for Question 11 is 2 marks)

- 12** Here are the first five terms of a number sequence.

$$7 \quad 10 \quad 13 \quad 16 \quad 19$$

- (a) Write down the next term of the sequence.

.....
(1)

- (b) Explain how you found your answer.

.....
(1)

- (c) Find the 11th term of the sequence.

.....
(1)

- (d) Explain why 60 cannot be a term of the sequence.

.....
(1)

(Total for Question 12 is 4 marks)

DO NOT WRITE IN THIS AREA

DO NOT WRITE IN THIS AREA

DO NOT WRITE IN THIS AREA



13 (a) Solve $4p + 7 = 12$

$$p = \dots\dots\dots$$

(2)

(b) Solve $8y - 18 = 3(y + 3)$
Show clear algebraic working.

$$y = \dots\dots\dots$$

(3)

(Total for Question 13 is 5 marks)

DO NOT WRITE IN THIS AREA

DO NOT WRITE IN THIS AREA

DO NOT WRITE IN THIS AREA



14 In a sale, all normal prices are reduced by 20%

- (a) The normal price of a television set is 485 euros.
Work out the sale price of the television set.

..... euros
(3)

- (b) In the sale, the normal price of a tablet computer is reduced by 79 euros.
Work out the normal price of the tablet computer.

..... euros
(3)

(Total for Question 14 is 6 marks)

DO NOT WRITE IN THIS AREA

DO NOT WRITE IN THIS AREA

DO NOT WRITE IN THIS AREA



15 (a) (i) Work out the value of $\frac{4.5 \times 8.43}{\sqrt{7.4 + 2.3}}$

Write down all the figures on your calculator display.

(ii) Give your answer to part (i) correct to 3 significant figures.

.....
(3)

(b) Find the cube root of 9261

.....
(1)

$$4^3 + 6^2 = 10^x$$

(c) Find the value of x

$x =$
(2)

(Total for Question 15 is 6 marks)

DO NOT WRITE IN THIS AREA

DO NOT WRITE IN THIS AREA

DO NOT WRITE IN THIS AREA

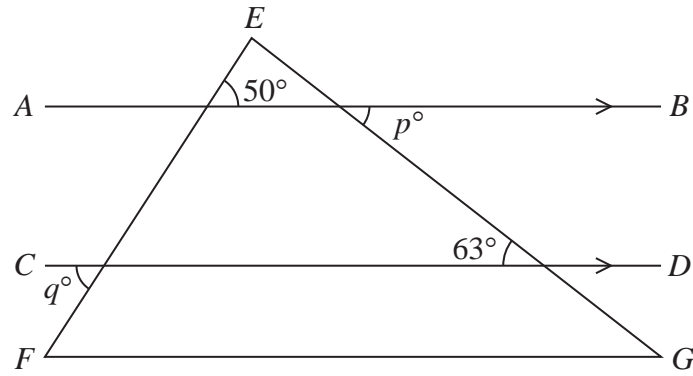

16

Diagram **NOT**
accurately drawn

DO NOT WRITE IN THIS AREA

DO NOT WRITE IN THIS AREA

DO NOT WRITE IN THIS AREA

EFG is a triangle.
 AB is parallel to CD .

(a) Write down the value of p

$$p = \dots\dots\dots (1)$$

(b) Write down the value of q

$$q = \dots\dots\dots (1)$$

Here is a hexagon.

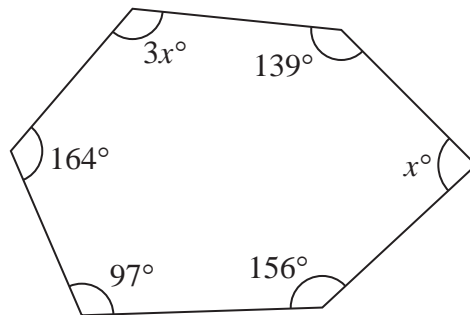
Diagram **NOT**
accurately drawn(c) Work out the value of x

$$x = \dots\dots\dots (3)$$

(Total for Question 16 is 5 marks)



DO NOT WRITE IN THIS AREA

DO NOT WRITE IN THIS AREA

DO NOT WRITE IN THIS AREA

17 (a) Simplify $7 \times e \times 2 \times d$

.....
(1)

(b) Simplify $m^5 \times m^2$

.....
(1)

(c) Simplify $c^{11} \div c^3$

.....
(1)

(d) Simplify $(a^5)^3$

.....
(1)

(e) Expand and simplify $4(2x + 3) + 2(x + 5)$

.....
(2)

(Total for Question 17 is 6 marks)



18

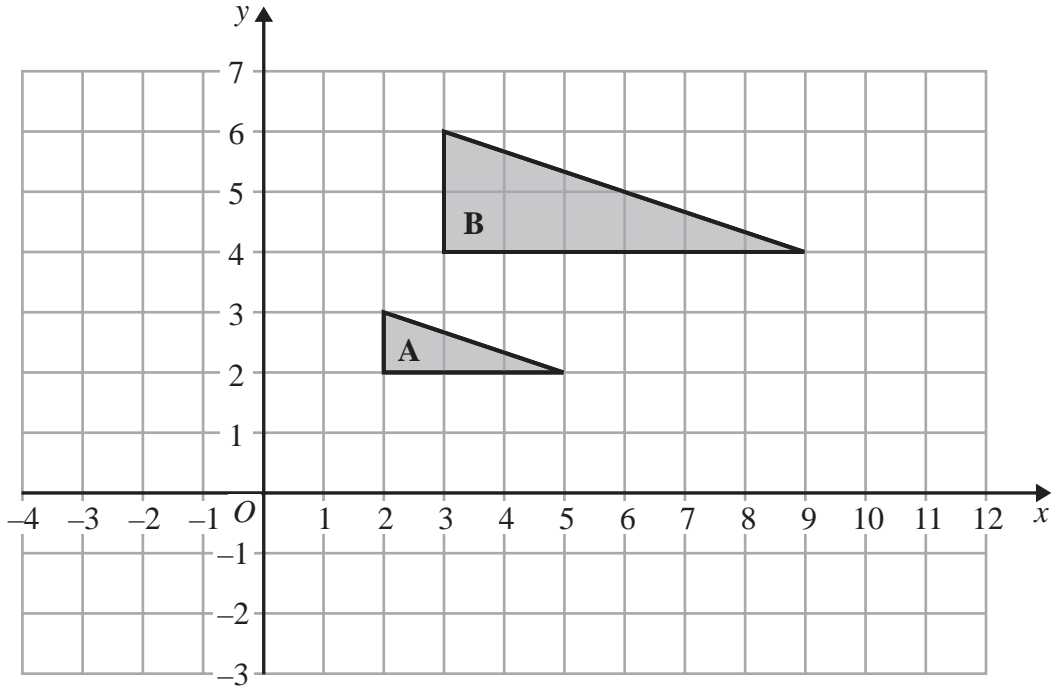

- (a) Describe fully the single transformation that maps triangle **A** onto triangle **B**.

(3)

- (b) On the grid, translate triangle **A** 5 units in the positive x direction and 4 units in the negative y direction.
Label the new shape **C**.

(1)

DO NOT WRITE IN THIS AREA

DO NOT WRITE IN THIS AREA

DO NOT WRITE IN THIS AREA

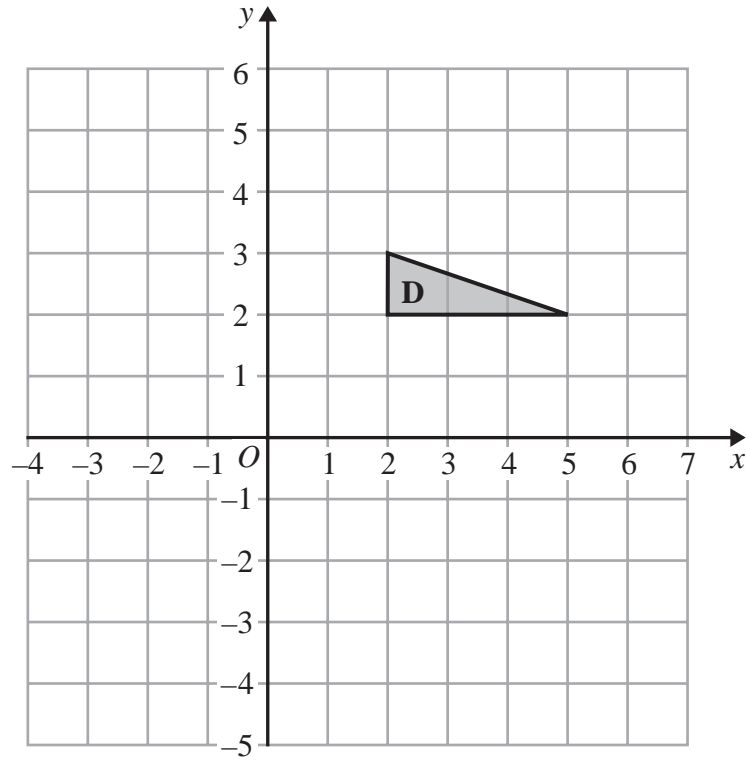

(c) On the grid, rotate triangle **D** 90° anticlockwise with centre (3, 1)

(2)

(Total for Question 18 is 6 marks)

- 19** Express 560 as a product of powers of its prime factors.
Show your working clearly.

.....
(Total for Question 19 is 3 marks)

- 20** Students in class 9Y took part in a sponsored swim.
The table gives information about the amount of money, in £, raised by each student.

Money raised (£ x)	Frequency
$0 \leq x < 6$	4
$6 \leq x < 12$	6
$12 \leq x < 18$	8
$18 \leq x < 24$	9
$24 \leq x < 30$	3

Work out an estimate for the total amount of money raised by the students in class 9Y.

£.....

(Total for Question 20 is 3 marks)



21 (a) Complete the table of values for $y = x^2 - 4x + 2$

x	-1	0	1	2	3	4	5
y		2		-2	-1		

(2)

(b) On the grid, draw the graph of $y = x^2 - 4x + 2$ for all values of x from -1 to 5

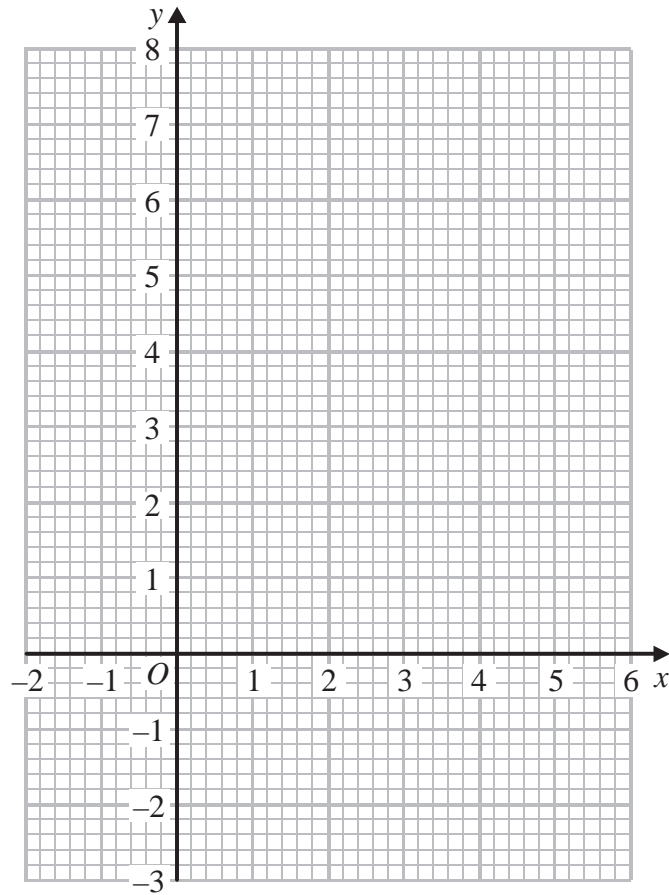

(2)

(Total for Question 21 is 4 marks)

DO NOT WRITE IN THIS AREA

DO NOT WRITE IN THIS AREA

DO NOT WRITE IN THIS AREA

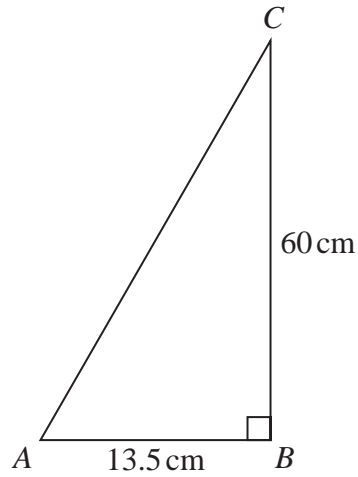

22

Diagram **NOT**
accurately drawn

- (a) Work out the perimeter of the triangle.

..... cm
(4)

- (b) The length of AB is 13.5 cm correct to 3 significant figures.
Write down the lower bound of the length of AB .

..... cm
(1)

(Total for Question 22 is 5 marks)

TOTAL FOR PAPER IS 100 MARKS

DO NOT WRITE IN THIS AREA

DO NOT WRITE IN THIS AREA

DO NOT WRITE IN THIS AREA



DO NOT WRITE IN THIS AREA

DO NOT WRITE IN THIS AREA

DO NOT WRITE IN THIS AREA

BLANK PAGE

Do NOT write on this page



DO NOT WRITE IN THIS AREA

DO NOT WRITE IN THIS AREA

DO NOT WRITE IN THIS AREA

BLANK PAGE

Do NOT write on this page

