

Write your name here	
Surname	Other names
Centre Number	Candidate Number
<b>Pearson Edexcel</b> <b>International GCSE (9 - 1)</b>	<div style="display: flex; justify-content: space-around;"> <div style="border: 1px solid black; width: 40px; height: 20px;"></div> <div style="border: 1px solid black; width: 40px; height: 20px;"></div> <div style="border: 1px solid black; width: 40px; height: 20px;"></div> <div style="border: 1px solid black; width: 40px; height: 20px;"></div> </div> <div style="display: flex; justify-content: space-around;"> <div style="border: 1px solid black; width: 40px; height: 20px;"></div> <div style="border: 1px solid black; width: 40px; height: 20px;"></div> <div style="border: 1px solid black; width: 40px; height: 20px;"></div> <div style="border: 1px solid black; width: 40px; height: 20px;"></div> </div>
<h1 style="margin: 0;">Physics</h1> <h2 style="margin: 0;">Paper 2</h2>	
Sample Assessment Material for first teaching September 2017	Paper Reference
<b>Time: 1 hour 15 minutes</b>	<b>4PH1/2P</b>
<b>You must have:</b> Calculator, ruler	Total Marks

### Instructions

- Use **black** ink or ball-point pen.
- **Fill in the boxes** at the top of this page with your name, centre number and candidate number.
- Answer **all** questions.
- Answer the questions in the spaces provided  
– *there may be more space than you need.*
- Calculators may be used.
- You must **show all your working out** with **your answer clearly identified** at the **end of your solution**.
- Some questions must be answered with a cross in a box ☒. If you change your mind about an answer, put a line through the box ☒ and then mark your new answer with a cross ☒.

### Information

- The total mark for this paper is 70.
- The marks for **each** question are shown in brackets  
– *use this as a guide as to how much time to spend on each question.*

### Advice

- Read each question carefully before you start to answer it.
- Try to answer every question.
- Check your answers if you have time at the end.

*Turn over* ►

S52918A

©2016 Pearson Education Ltd.



PEARSON

## EQUATIONS

You may find the following equations useful.

$$\text{energy transferred} = \text{current} \times \text{voltage} \times \text{time}$$

$$E = I \times V \times t$$

$$\text{frequency} = \frac{1}{\text{time period}}$$

$$f = \frac{1}{T}$$

$$\text{power} = \frac{\text{work done}}{\text{time taken}}$$

$$P = \frac{W}{t}$$

$$\text{power} = \frac{\text{energy transferred}}{\text{time taken}}$$

$$P = \frac{W}{t}$$

$$\text{orbital speed} = \frac{2\pi \times \text{orbital radius}}{\text{time period}}$$

$$V = \frac{2 \times \pi \times r}{T}$$

$$(\text{final speed})^2 = (\text{initial speed})^2 + (2 \times \text{acceleration} \times \text{distance moved})$$

$$v^2 = u^2 + (2 \times a \times s)$$

$$\text{pressure} \times \text{volume} = \text{constant}$$

$$p_1 \times V_1 = p_2 \times V_2$$

$$\frac{\text{pressure}}{\text{temperature}} = \text{constant}$$

$$\frac{p_1}{T_1} = \frac{p_2}{T_2}$$

$$\text{force} = \frac{\text{change in momentum}}{\text{time taken}}$$

$$F = \frac{(mv - mu)}{t}$$

$$\frac{\text{change of wavelength}}{\text{wavelength}} = \frac{\text{velocity of a galaxy}}{\text{speed of light}}$$

$$\frac{\lambda - \lambda_0}{\lambda_0} = \frac{\Delta\lambda}{\lambda_0} = \frac{v}{c}$$

$$\text{change in thermal energy} = \text{mass} \times \text{specific heat capacity} \times \text{change in temperature}$$

$$\Delta Q = m \times c \times \Delta T$$

Where necessary, assume the acceleration of free fall,  $g = 10 \text{ m/s}^2$ .

DO NOT WRITE IN THIS AREA

DO NOT WRITE IN THIS AREA

DO NOT WRITE IN THIS AREA

DO NOT WRITE IN THIS AREA

DO NOT WRITE IN THIS AREA

DO NOT WRITE IN THIS AREA

**TURN THE PAGE OVER FOR QUESTION 1**

**Answer ALL questions. Write your answers in the spaces provided.**

**1** A tennis racket is used to hit a tennis ball.

The ball is in contact with the racket for 0.20 seconds and leaves the racket with a horizontal velocity of 46 m/s.

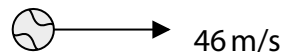
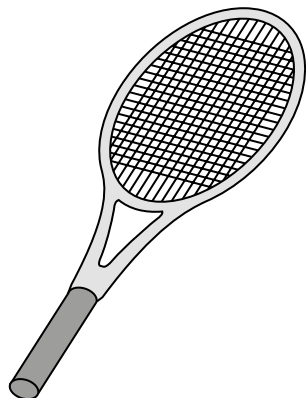

(a) (i) State the equation relating acceleration, change in velocity and time taken. (1)

(ii) Calculate the acceleration of the tennis ball assuming it is at rest when it is hit.  
Give the unit. (3)

acceleration = ..... unit .....

DO NOT WRITE IN THIS AREA

DO NOT WRITE IN THIS AREA

DO NOT WRITE IN THIS AREA

DO NOT WRITE IN THIS AREA

DO NOT WRITE IN THIS AREA

DO NOT WRITE IN THIS AREA

(b) The tennis ball has a mass of 57 grams.

(i) State the equation relating momentum, mass and velocity. (1)

(ii) Calculate the momentum of the tennis ball when its velocity is 46 m/s. (3)

momentum = ..... kg m/s

(c) The bottom of a tennis player's shoes are thick and made from a material that compresses when the player's feet land on the ground.

Explain why these shoes reduce the risk of injury to the tennis player. (3)

.....

.....

.....

.....

.....

.....

.....

.....

**(Total for Question 1 = 11 marks)**

**2** Lightning strikes the Earth frequently and often starts in rain clouds.

Inside the clouds, powerful winds move ice particles and tiny water droplets.

The bottom of the clouds becomes negatively charged and the top becomes positively charged.

(a) Give a reason why the clouds become charged.

(1)

(b) The ground below the cloud becomes positively charged.

Explain why the ground becomes charged.

You should use ideas about electron movement in your answer.

(2)

(c) The build-up of charge in the cloud and in the ground causes the air to ionise.

This means that the air becomes a conductor, and a low resistance path from the cloud to the ground is formed.

(i) State what is meant by the term **ionise**.

(1)

(ii) State the relationship between charge, current and time.

(1)

DO NOT WRITE IN THIS AREA

DO NOT WRITE IN THIS AREA

DO NOT WRITE IN THIS AREA

- (iii) During one lightning strike, the mean current is 32 kA and the mean charge transferred is 15 C.

Calculate the mean time duration of a lightning strike.

(2)

mean time = ..... s

- (iv) The mean energy transferred during the lightning strike is  $510 \times 10^6$  J.

Show that the resistance of the air is approximately  $1000 \Omega$ .

(4)

**(Total for Question 2 = 11 marks)**

DO NOT WRITE IN THIS AREA

DO NOT WRITE IN THIS AREA

DO NOT WRITE IN THIS AREA

**3** Wind is a renewable resource used to generate electricity.

(a) (i) State **one** advantage and **one** disadvantage of producing electricity using wind turbines.

(2)

Advantage.....  
.....

Disadvantage.....  
.....

(ii) The graph shows how the power output of a wind turbine varies with wind speed.

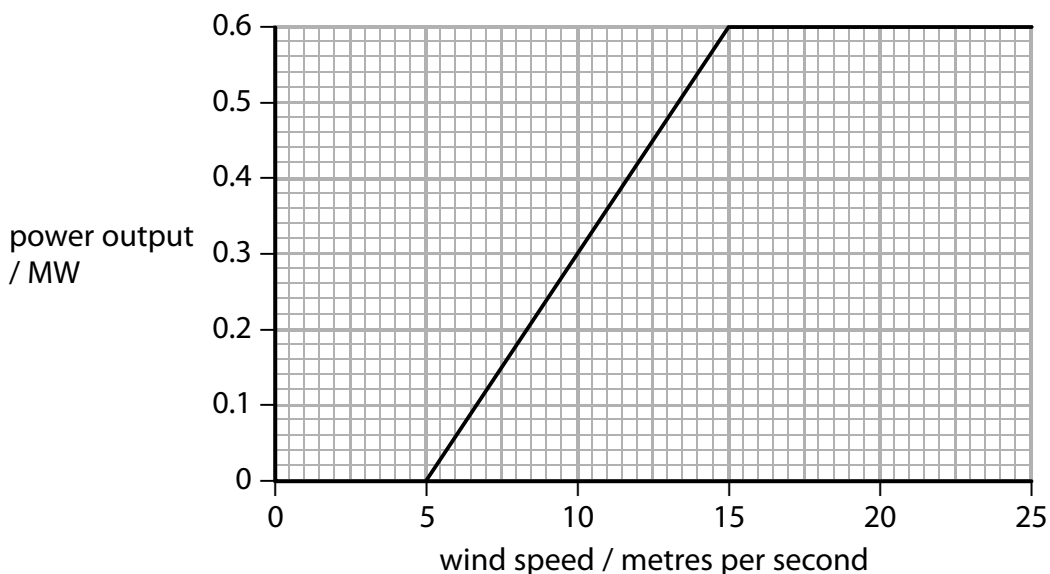

Describe how the power output of a wind turbine varies with wind speed.

You should use data points from the graph in your answer.

(3)

.....  
.....  
.....  
.....  
.....  
.....

DO NOT WRITE IN THIS AREA

DO NOT WRITE IN THIS AREA

DO NOT WRITE IN THIS AREA



4 This question is about heating water.

(a) Liquid water boils and becomes a gas at  $100^{\circ}\text{C}$ .

Describe the differences between the arrangement and motion of particles in a liquid and in a gas.

You may include a diagram in your answer.

(3)

.....

.....

.....

.....

.....

.....

(b) A teacher uses a 2200W kettle to heat water.

The kettle is switched on for 2 minutes.

(i) Calculate the energy transferred by the kettle.

(3)

energy transferred = ..... J

DO NOT WRITE IN THIS AREA

DO NOT WRITE IN THIS AREA

DO NOT WRITE IN THIS AREA

DO NOT WRITE IN THIS AREA

DO NOT WRITE IN THIS AREA

DO NOT WRITE IN THIS AREA

(ii) State the equation relating change in thermal energy, mass, specific heat capacity and change in temperature.

(1)

(iii) The mass of water in the kettle is 1.1 kg and its initial temperature is 20°C.

Calculate the final temperature of the water after it has been heated for 2.0 minutes.

[the specific heat capacity of water is 4200 J/kg °C]

(4)

final temperature = ..... °C

(c) The teacher measures the final temperature of the water after heating it for 2 minutes.

(i) Name a piece of equipment the teacher could use to measure the temperature of the water.

(1)

(ii) Explain why the measured final temperature is different from your calculated value.

(2)

**(Total for Question 4 = 14 marks)**

- 5 A student investigates how the minimum current required to support a load using an electromagnet varies as the load is increased.  
 He uses metal discs to increase the load and changes the current using a variable resistor.

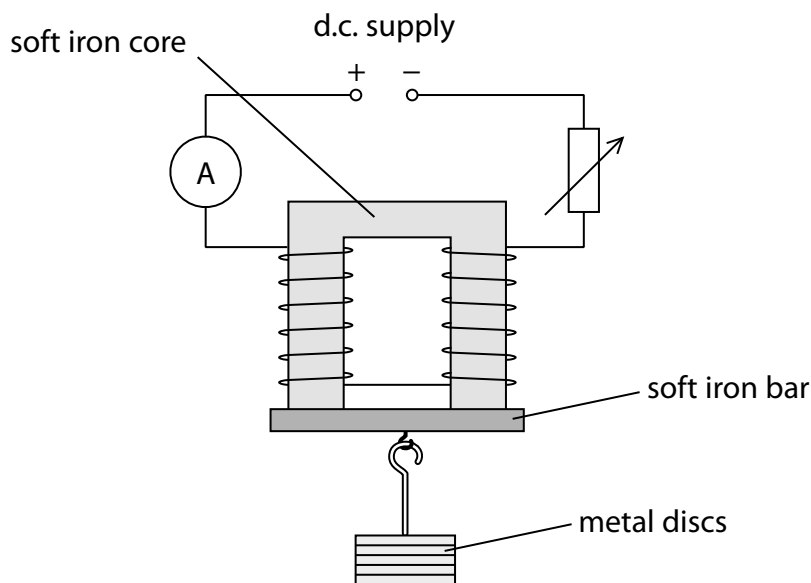

(a) (i) State the independent variable in this investigation. (1)

(ii) Give a reason for using a core and a bar made from soft iron. (1)

DO NOT WRITE IN THIS AREA

DO NOT WRITE IN THIS AREA

DO NOT WRITE IN THIS AREA

(b) The student's results are given in the table.

Number of metal discs	Minimum current / mA
0	30
2	48
5	75
6	78
7	93
10	120

(i) On the grid, draw a bar chart of current against number of metal discs.

(4)

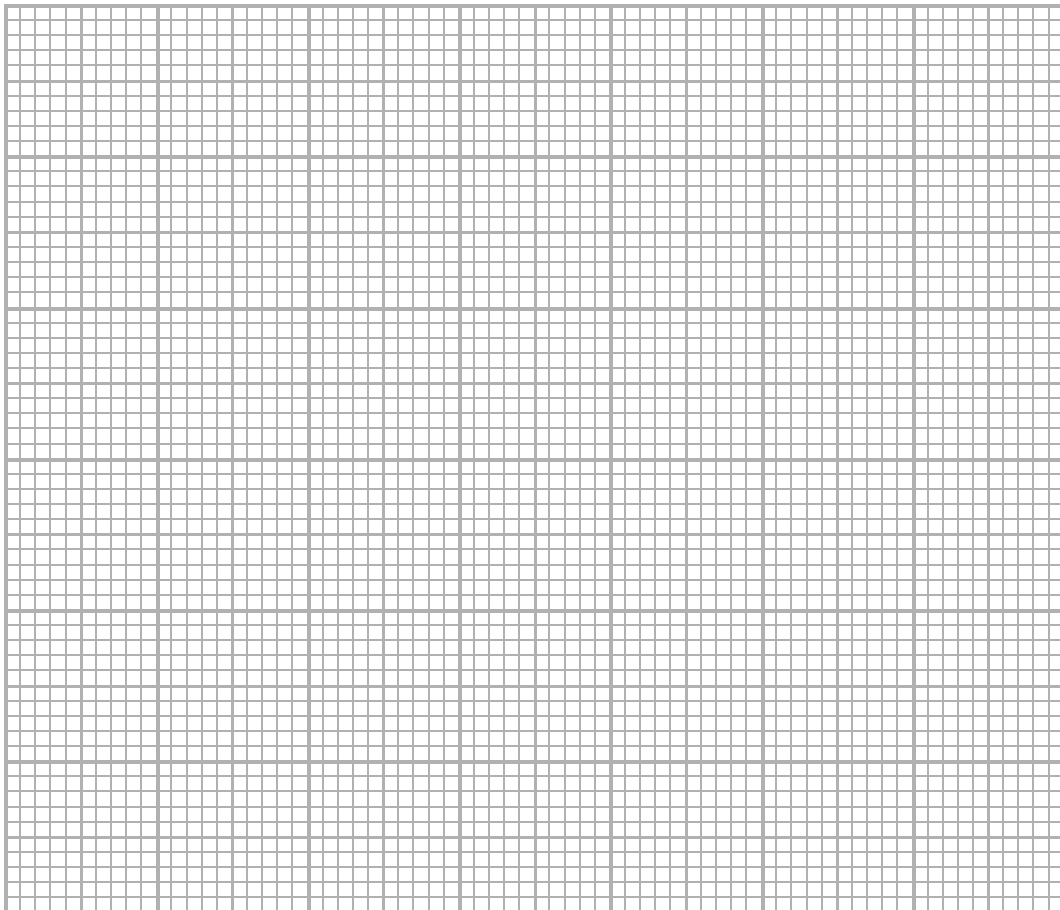

(ii) State why a current is needed when there are no metal discs added to the load.

(1)

(iii) Explain how the student can improve his results.

(3)

**(Total for Question 5 = 10 marks)**

DO NOT WRITE IN THIS AREA

DO NOT WRITE IN THIS AREA

DO NOT WRITE IN THIS AREA

6 This question is about astrophysics.

(a) (i) What is a star formed from?

(1)

- A a black dwarf
- B a nebula
- C a planet
- D a white dwarf

(ii) Which of these indicates that the Universe is expanding?

(1)

- A galaxies are moving further away from each other
- B galaxies rotate
- C it takes millions of light years for light to reach us from some stars
- D some stars in the Milky Way are accelerating towards our Sun

(iii) Which of these provides evidence for the Big Bang theory?

(1)

- A cosmic microwave background radiation
- B nebulae
- C neutron stars
- D ultrasound radiation

(iv) Which of these does red-shift provide evidence for?

(1)

- A galaxies are moving away from each other
- B nebulae contract to form stars
- C red giants shrink to red dwarfs
- D white dwarfs expand into red giants

DO NOT WRITE IN THIS AREA

DO NOT WRITE IN THIS AREA

DO NOT WRITE IN THIS AREA

DO NOT WRITE IN THIS AREA

DO NOT WRITE IN THIS AREA

DO NOT WRITE IN THIS AREA

(b) The spectra of stars and galaxies show lines at specific wavelengths that correspond to the spectra of hydrogen, helium and carbon.

Give reasons why lines corresponding to these elements are found in spectra from typical galaxies.

(2)

.....

.....

.....

.....

(c) The spectrum of light from an astronomical object called a quasar can be compared to the spectrum of hydrogen on Earth.

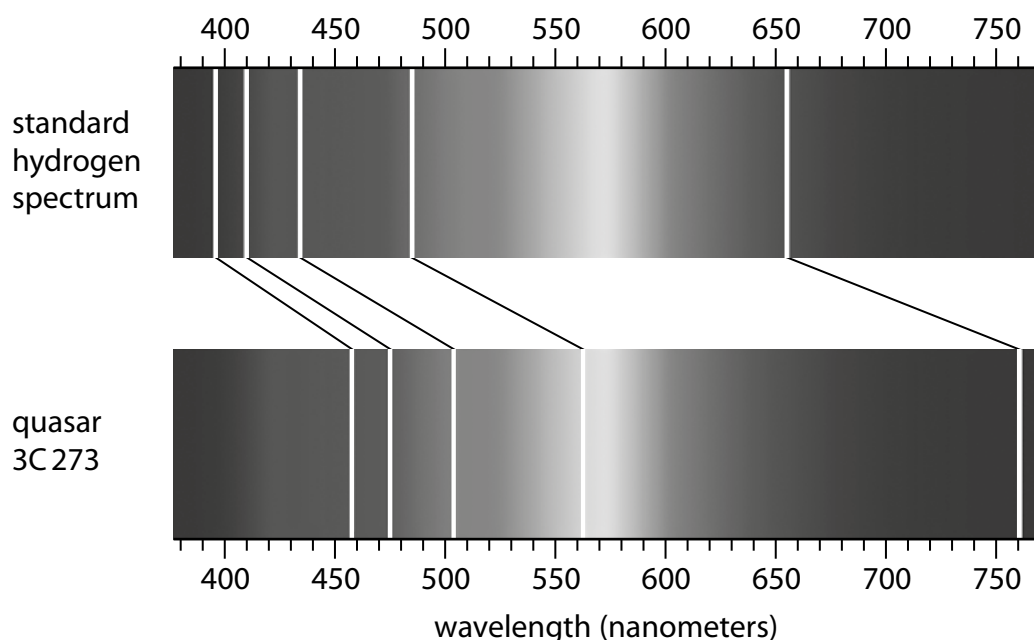

(i) Calculate the change in wavelength,  $\Delta\lambda$ , for the line at the red end of the spectrum.

(2)

$\Delta\lambda = \dots\dots\dots$  nm

- (ii) Calculate a value for the recessional velocity of the quasar using your value for  $\Delta\lambda$ .

speed of light in free space,  $c = 3.0 \times 10^5$  km/s

(3)

recessional velocity = ..... km/s

DO NOT WRITE IN THIS AREA

DO NOT WRITE IN THIS AREA

DO NOT WRITE IN THIS AREA

DO NOT WRITE IN THIS AREA

DO NOT WRITE IN THIS AREA

DO NOT WRITE IN THIS AREA

(d) An astronomer observes the light from a nearby galaxy.

She notices that the spectra for hydrogen from the right side and left side of the galaxy are different.

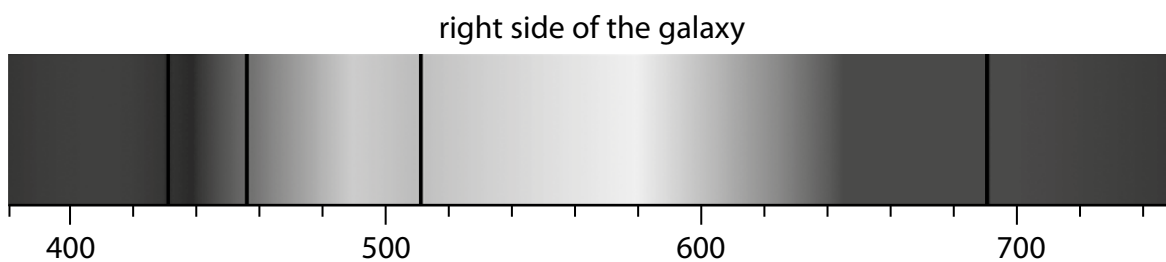
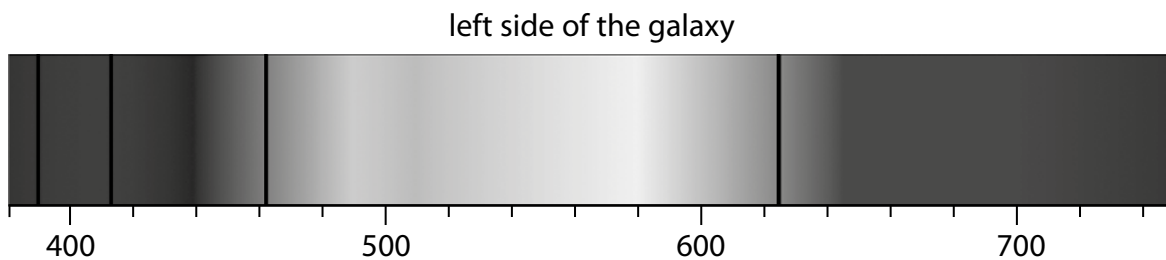

She compares them to the spectrum for hydrogen from the centre of the galaxy.

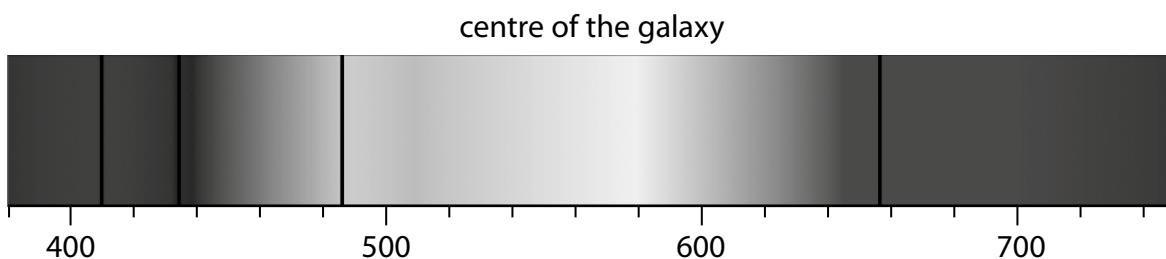

Explain what information the two spectra give about the movement of the galaxy.

(3)

.....

.....

.....

.....

.....

.....

.....

**(Total for Question 6 = 14 marks)**

**TOTAL FOR PAPER = 70 MARKS**

DO NOT WRITE IN THIS AREA

DO NOT WRITE IN THIS AREA

DO NOT WRITE IN THIS AREA

DO NOT WRITE IN THIS AREA

DO NOT WRITE IN THIS AREA

DO NOT WRITE IN THIS AREA

**BLANK PAGE**